



KARTING BRAKES AND CLUTCHES

2024

BRAKING SPECIALISTS SINCE 1969



At sinter, we design, produce, and test our products in slovenia to ensure the highest quality standards. With our own in-house development, **we lead the way in brake technology.**



55 YEAR TRADITION OF DEVELOPING FRICTION MATERIAL



Sinter's premium organic disc pads are not a replacement, but an **upgrade to your braking system.**



SINTER FRICTION MATERIALS

We produce more than 500 types of brake pads, made of a couple of own friction mixtures. We also provide custom mixtures. **All brake pads available in the following three materials:**

BLACK

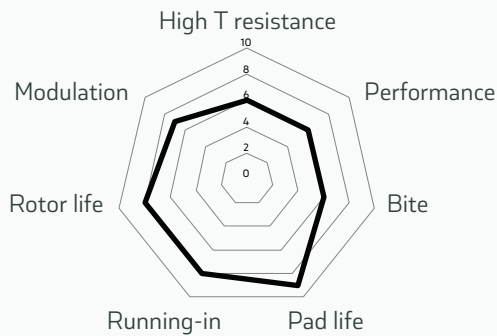

S-205 RENTAL

This material is designed for low wear and with a stable friction coefficient.

- / LONG-LASTING PERFORMANCE**
- / ORGANIC FORMULATION, LOW COPPER CONTENT**
- / FAST BEDDING IN**
- / SUITABLE FOR RENTAL APPLICATION**

RED

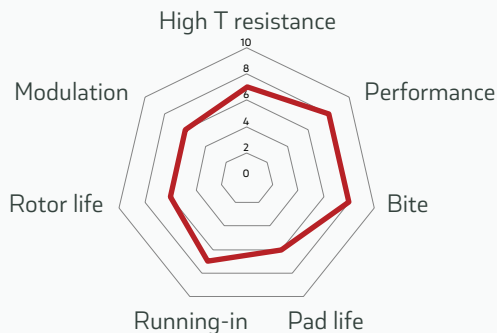

S-222 RACE

This material is designed for maximum go-kart braking loads. It performs best with grey cast iron braking disks.

- / EXCELLENT PERFORMANCE**
- / POWERFUL INITIAL BITE**
- / SEMI-METALLIC MIXTURE**
- / SUITABLE FOR RACING APPLICATION**

GREEN

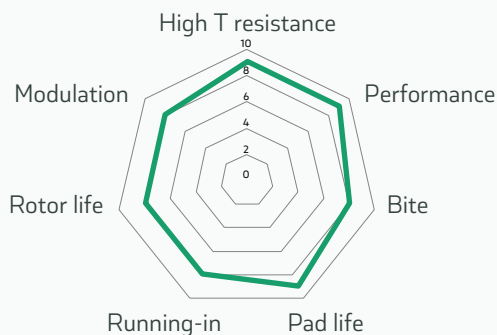

S-230 ELITE

New racing formulation for the most demanding racers. Great modulation provides total control of your brakes.

- / OVERALL CHAMPION**
- / RACING COMPOUND**
- / NO COMPROMISE**
- / GREAT MODULATION**

CUSTOM

Sinter's own r&d and production department can always provide custom friction mixtures per request. With our rich knowledge we can help the customer experiment and decide on the specification.



BEDDING-IN PROCEDURE

In order to ensure optimal braking performance and the best racing experience each new set of brake pads has to undergo bedding-in procedure when assembled in the braking system.

During this important phase brake pad surface is being adjusted against the brake disc surface and a transfer layer on the brake disc surface is being developed. This significantly affects friction and wear performance of the brake couple.

Sinter recommends the following bedding-in procedure:

- 1 Make sure the brake disc and the brake pads have been properly installed.
 - 2 Brake disc and brake pad surface should be clean and dry.
 - 3 Start slowly and brake lightly pushing the pedal for a couple of seconds in order to slow down without making a complete stop. Repeat 20 times.
 - 4 Allow brakes to cool down.
 - 5 Proceed with gradual speed increase for 5-10 laps. During this phase brake moderately without any hard stops.
 - 6 Allow the brakes to cool after each lap.
 - 7 Finish the bedding-in procedure with high speed and hard braking for 2-3 laps.
 - 8 Allow the brakes to cool down.
 - 9 Get ready to race! Your brakes already are.
- 

BRAKE PADS

027-0

Height (mm) - **51,4** Thickness (mm) - **10,0**
Lenght (mm) - **59,3** Thread - /



027-1

Height (mm) - **51,4** Thickness (mm) - **10,5**
Lenght (mm) - **59,3** Thread - /

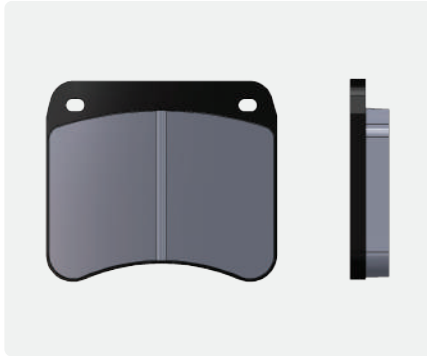

027-2

Height (mm) - **51,4** Thickness (mm) - **13,3**
Lenght (mm) - **108,8** Thread - /



027-6

Height (mm) - **51,4** Thickness (mm) - **10,0**
Lenght (mm) - **59,3** Thread - /

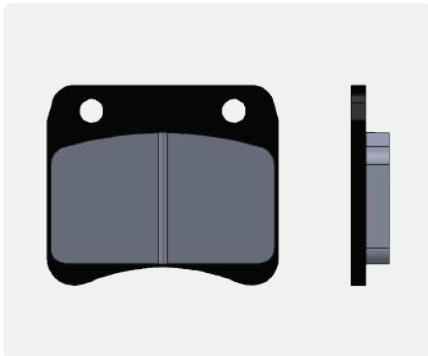

092-0

Height (mm) - **42,0** Thickness (mm) - **11,0**
Lenght (mm) - **97,0** Thread - **M6 82mm**

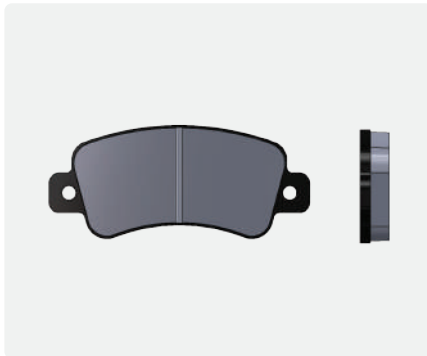

092-5

Height (mm) - **42,0** Thickness (mm) - **14,5**
Lenght (mm) - **97,0** Thread - **M6 82mm**

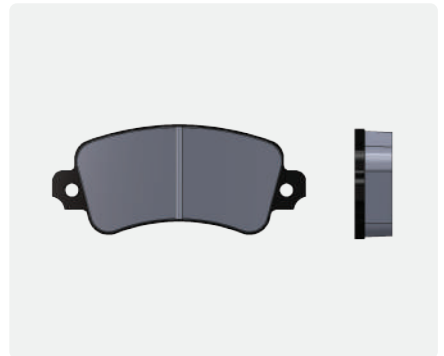

098-0

Height (mm) - **53,3** Thickness (mm) - **14,5**
Lenght (mm) - **55,5** Thread - /

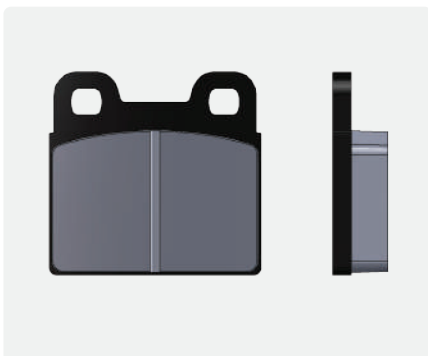

108-0

Height (mm) - **60,0** Thickness (mm) - **12,0**
Lenght (mm) - **54,0** Thread - /

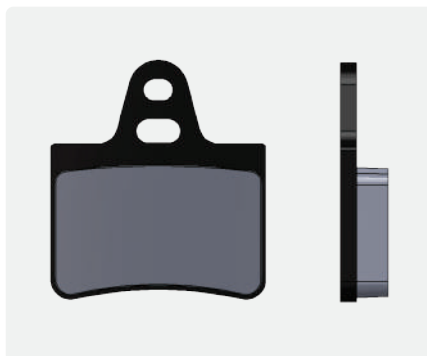

296-5

Height (mm) - **62,8** Thickness (mm) - **17,5**
Lenght (mm) - **90,0** Thread - /

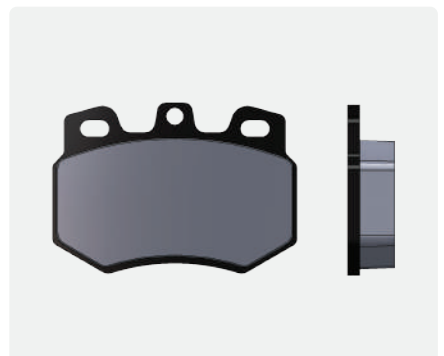

340-0

Height (mm) - **59,8** Thickness (mm) - **14,0**
Lenght (mm) - **78,3** Thread - /

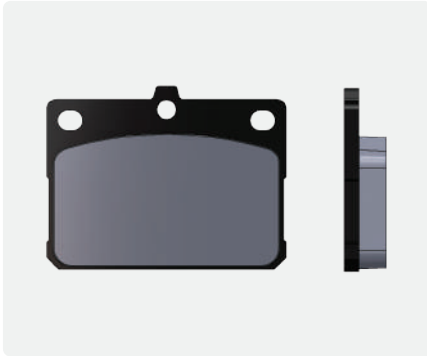

359-0

Height (mm) - **51,0** Thickness (mm) - **15,0**
Lenght (mm) - **61,7** Thread - /

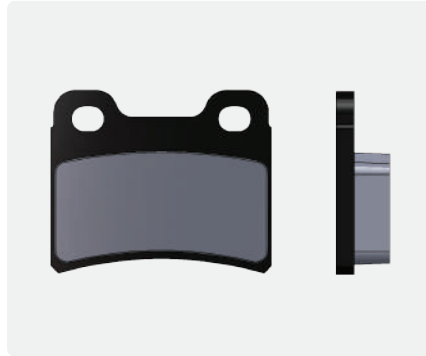

401-1

Height (mm) - **51,5** Thickness (mm) - **15,0**
Lenght (mm) - **85,0** Thread - **M6 74mm**

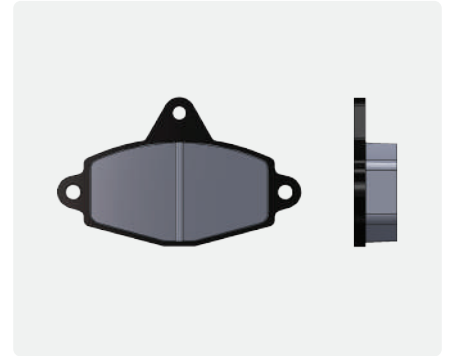

401-2

Height (mm) - **51,5** Thickness (mm) - **10,2**
Lenght (mm) - **85,0** Thread - **M6 74mm**

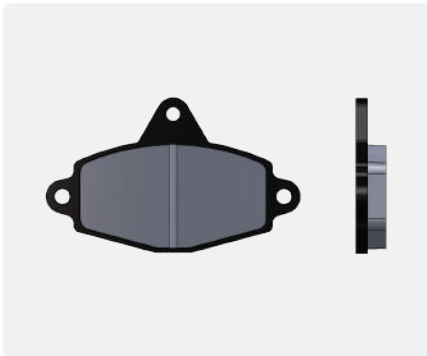

401-3

Height (mm) - **51,5** Thickness (mm) - **13,0**
Lenght (mm) - **85,0** Thread - **M6 74mm**

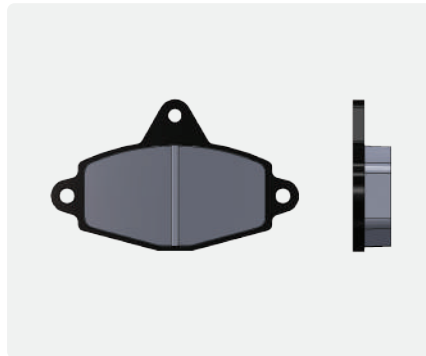

402-0

Height (mm) - **48,0** Thickness (mm) - **10,0**
Lenght (mm) - **43,0** Thread - /

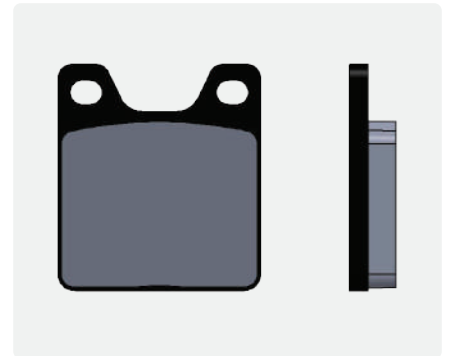

403-0

Height (mm) - **49,8** Thickness (mm) - **8,5**
Lenght (mm) - **37,9** Thread - /

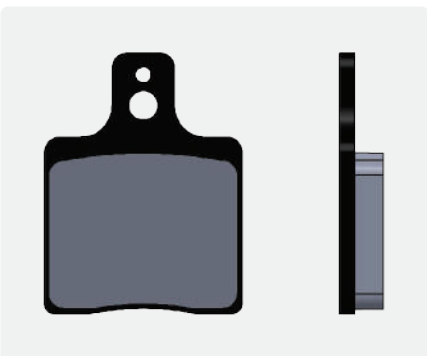

405-0

Height (mm) - **52,0** Thickness (mm) - **13,0**
Lenght (mm) - **90,0** Thread - **M6 65mm**

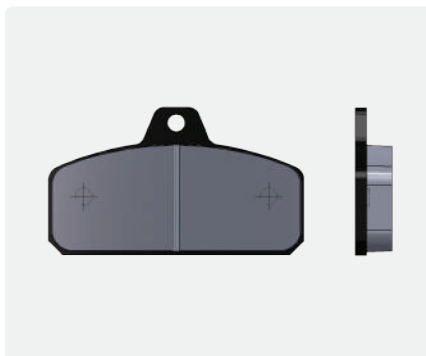

405-1

Height (mm) - **52,0** Thickness (mm) - **16,0**
Lenght (mm) - **90,0** Thread - **M6 65mm**

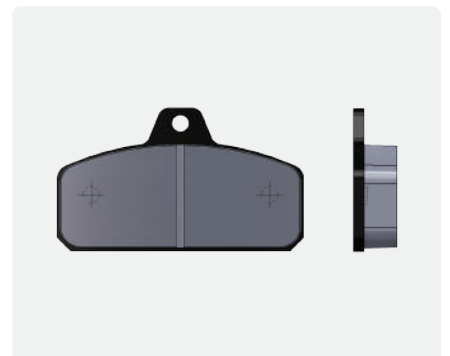

BRAKE PADS

405-2

Height (mm) - **52,0** Thickness (mm) - **16,0**
Lenght (mm) - **90,0** Thread - **M5 65mm**

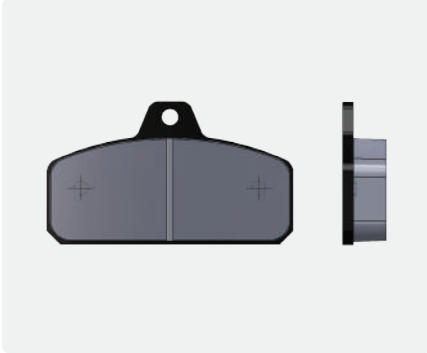

405-3

Height (mm) - **52,0** Thickness (mm) - **11,5**
Lenght (mm) - **90,0** Thread - **M6 65mm**

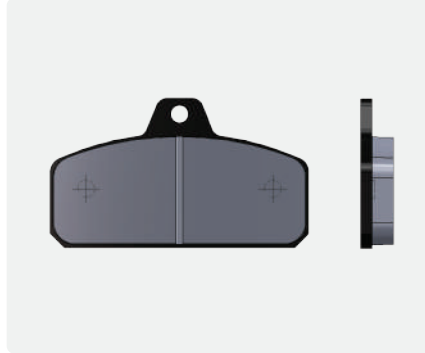

405-4

Height (mm) - **52,0** Thickness (mm) - **16,0**
Lenght (mm) - **90,0** Thread - **M6 80mm**

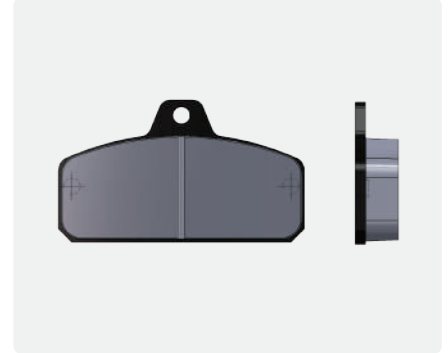

406-0

Height (mm) - **52,0** Thickness (mm) - **13,0**
Lenght (mm) - **90,0** Thread - **M6 65mm**

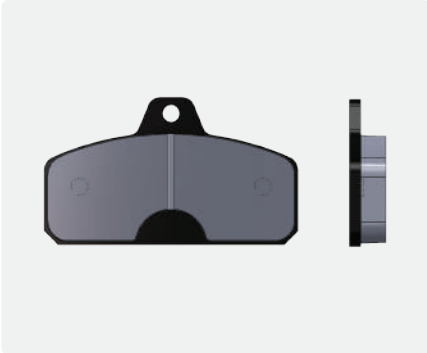

406-1

Height (mm) - **52,0** Thickness (mm) - **16,0**
Lenght (mm) - **90,0** Thread - **M6 65mm**

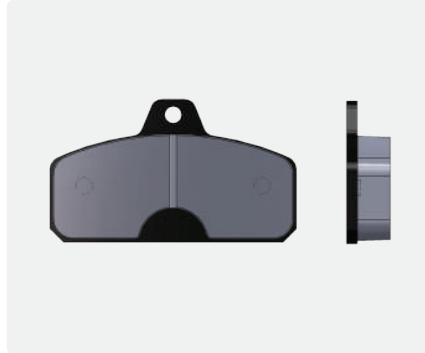

406-2

Height (mm) - **52,0** Thickness (mm) - **16,0**
Lenght (mm) - **90,0** Thread - **M5 65mm**

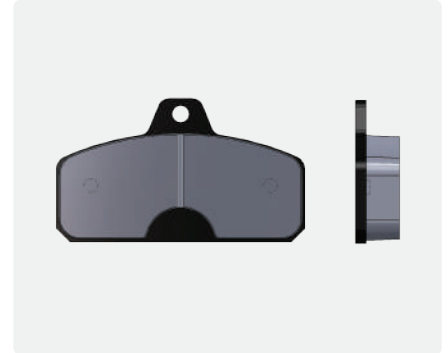

406-4

Height (mm) - **52,0** Thickness (mm) - **16,0**
Lenght (mm) - **90,0** Thread - **M6 80mm**

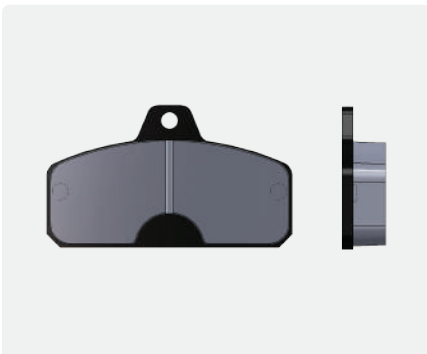

407-0

Height (mm) - **42,9** Thickness (mm) - **9,5**
Lenght (mm) - **65,9** Thread - **M5 59mm**

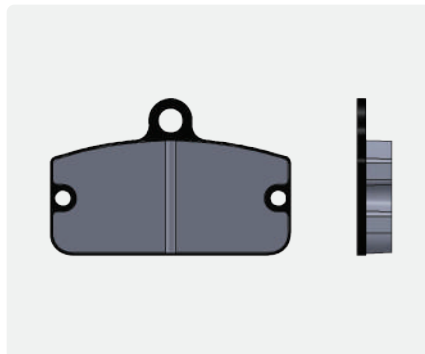

408-0

Height (mm) - **45,5** Thickness (mm) - **12,0**
Lenght (mm) - **86,0** Thread - **M6 76mm**

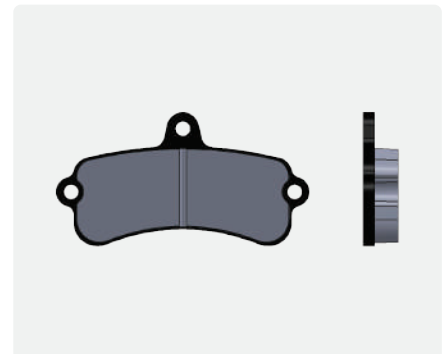

409-0

Height (mm) - **43,5** Thickness (mm) - **12,0**
Lenght (mm) - **56,0** Thread - /

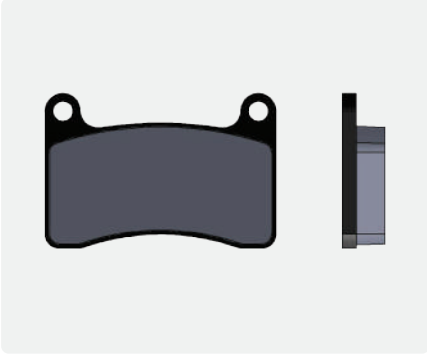

410-0

Height (mm) - **52,0** Thickness (mm) - **10,0**
Lenght (mm) - **75,1** Thread - **M6 60mm**

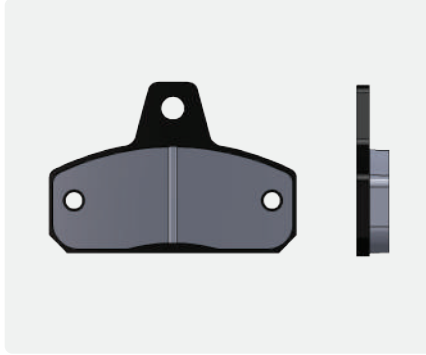

413-0

Height (mm) - **40,0** Thickness (mm) - **9,0**
Lenght (mm) - **52,5** Thread - /

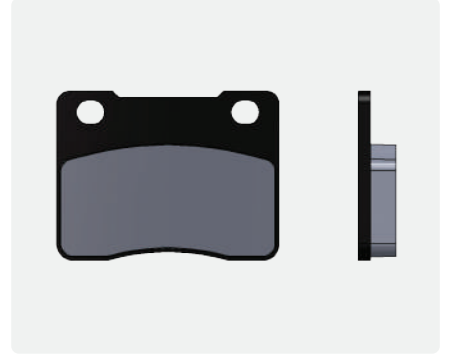

414-0

Height (mm) - **43,4** Thickness (mm) - **12,0**
Lenght (mm) - **76,0** Thread - /

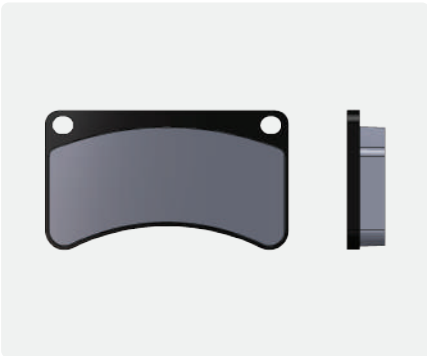

417-0

Height (mm) - **52,3** Thickness (mm) - **13,0**
Lenght (mm) - **89,5** Thread - **M6 65/80mm**

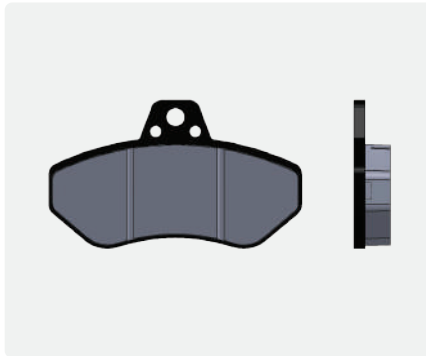

417-1

Height (mm) - **52,3** Thickness (mm) - **16,0**
Lenght (mm) - **89,5** Thread - **M6 65/80mm**

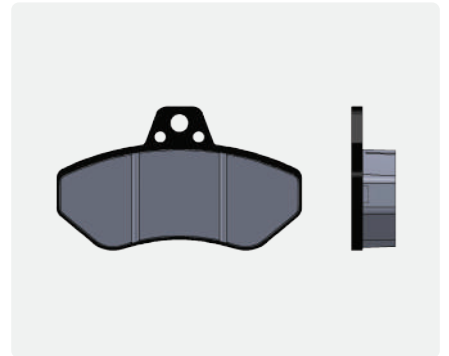

417-2

Height (mm) - **52,3** Thickness (mm) - **18,0**
Lenght (mm) - **89,5** Thread - **M6 65/80mm**

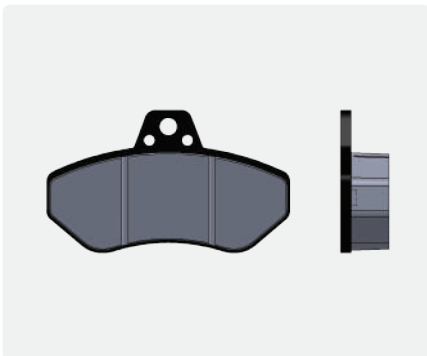

419-0

Height (mm) - **43,5** Thickness (mm) - **8,0**
Lenght (mm) - **60,0** Thread - **M5 50mm**

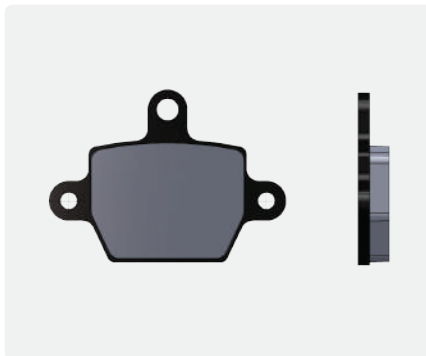

423-0

Height (mm) - **36,5** Thickness (mm) - **11,0**
Lenght (mm) - **45,0** Thread - /

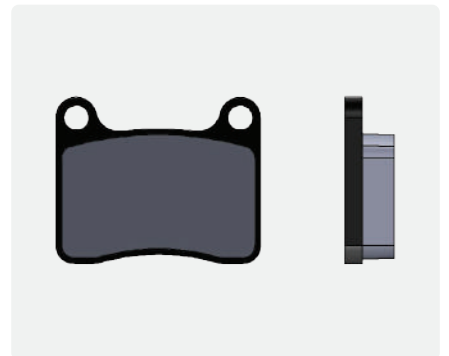

BRAKE PADS

424-0

Height (mm) - **60,4** Thickness (mm) - **10,0**
Lenght (mm) - **56,0** Thread - /

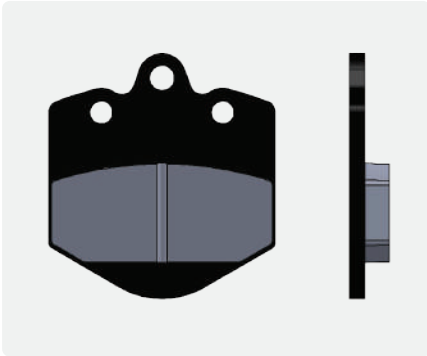

425-0

Height (mm) - **43,6** Thickness (mm) - **10,0**
Lenght (mm) - **57,2** Thread - **M4 46mm**

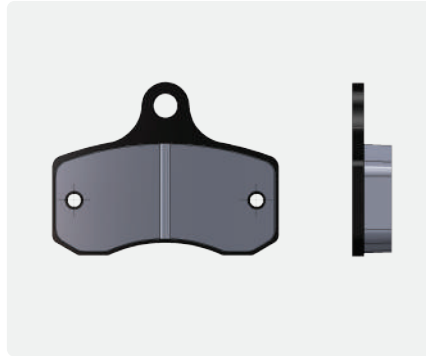

429-0

Height (mm) - **39,1** Thickness (mm) - **12,0**
Lenght (mm) - **60,0** Thread - /

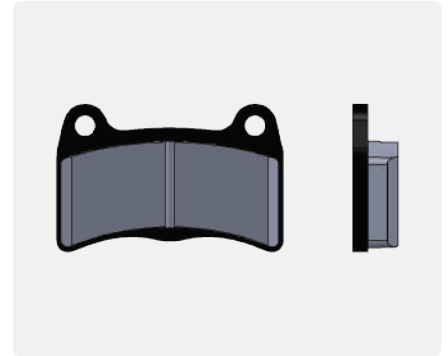

430-0

Height (mm) - **26,4** Thickness (mm) - **13,0**
Lenght (mm) - **67,3** Thread - **M4*54mm**



430-1

Height (mm) - **26,4** Thickness (mm) - **13,0**
Lenght (mm) - **67,3** Thread - **M5*54mm**



430-3

Height (mm) - **26,4** Thickness (mm) - **12,0**
Lenght (mm) - **67,3** Thread - **M4*48mm**



431-0

Height (mm) - **49,8** Thickness (mm) - **12,0**
Lenght (mm) - **55,6** Thread - /

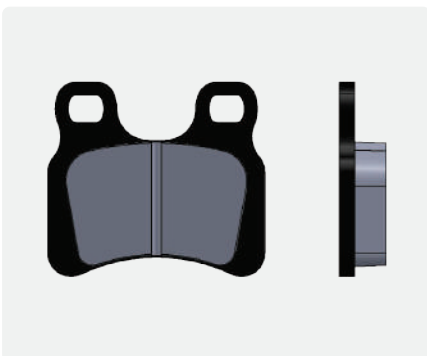

433-0

Height (mm) - **42,9** Thickness (mm) - **8,5**
Lenght (mm) - **41,1** Thread - /



434-0

Height (mm) - **42,9** Thickness (mm) - **7,5**
Lenght (mm) - **41,1** Thread - /



434-1

Height (mm) - **42,9** Thickness (mm) - **10,0**
Lenght (mm) - **41,1** Thread - /

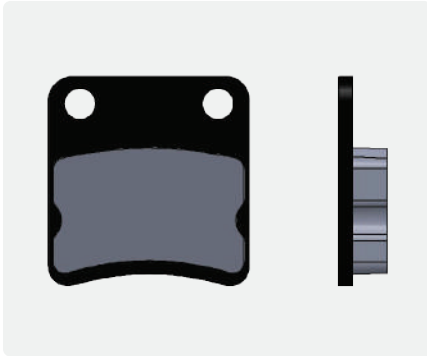

435-0

Height (mm) - **43,0** Thickness (mm) - **14,0**
Lenght (mm) - **112,0** Thread - **M6 56mm**

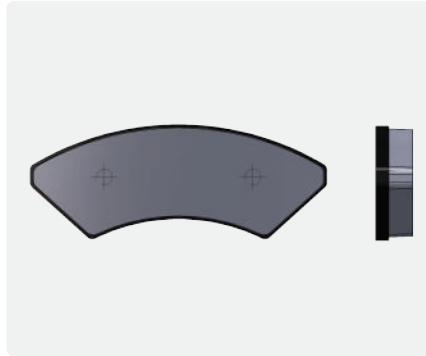

436-0

Height (mm) - **44,5** Thickness (mm) - **8,0**
Lenght (mm) - **39,0** Thread - /

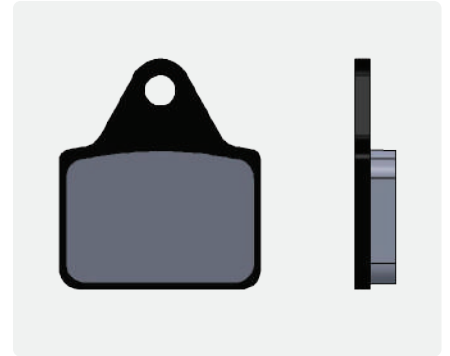

438-0

Height (mm) - **55,5** Thickness (mm) - **14,0**
Lenght (mm) - **59,6** Thread - **M6 26,9mm**

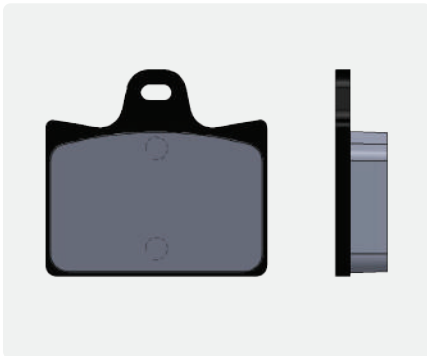

438-1

Height (mm) - **55,5** Thickness (mm) - **14,0**
Lenght (mm) - **59,6** Thread - **M6 26,9/49mm**

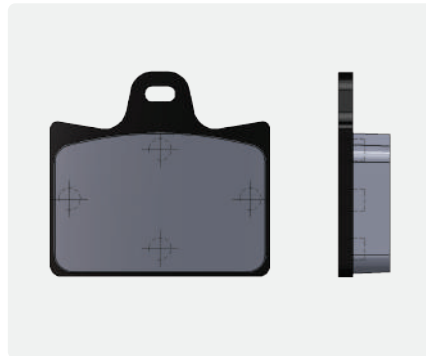

439-0

Height (mm) - **38,5** Thickness (mm) - **16,5**
Lenght (mm) - **95,2** Thread - /

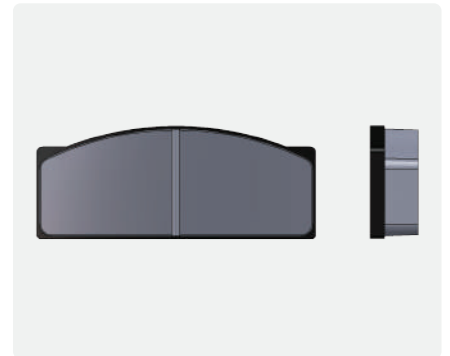

441-2

Height (mm) - **39,0** Thickness (mm) - **12,0**
Lenght (mm) - **99,0** Thread - **M6* 65mm**

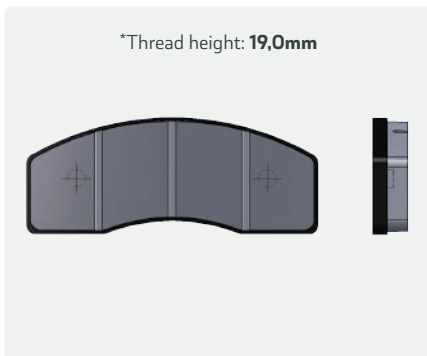

442-0

Height (mm) - **51,0** Thickness (mm) - **9,0**
Lenght (mm) - **48,0** Thread - /

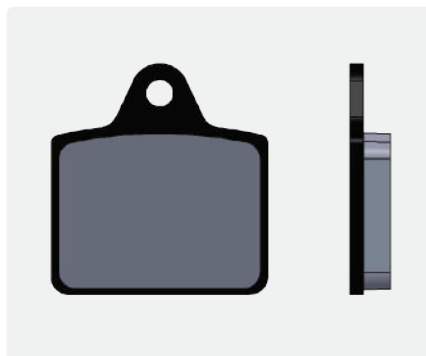

445-0

Height (mm) - **38,8** Thickness (mm) - **13,0**
Lenght (mm) - **91,1** Thread - **M6 65mm**

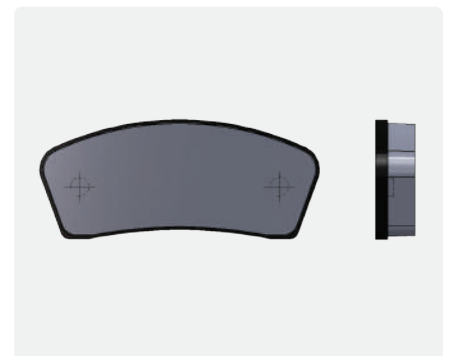

BRAKE PADS

445-1

Height (mm) - **38,8** Thickness (mm) - **13,0**
Lenght (mm) - **91,1** Thread - **M6 56,5mm**

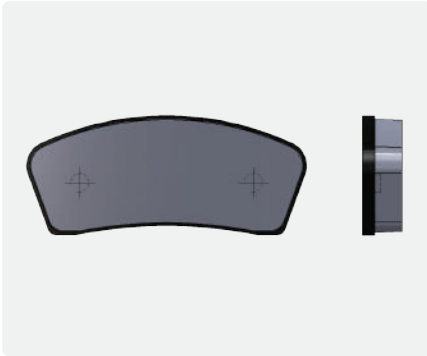

445-2

Height (mm) - **38,8** Thickness (mm) - **13,0**
Lenght (mm) - **91,1** Thread - **M5 65mm**

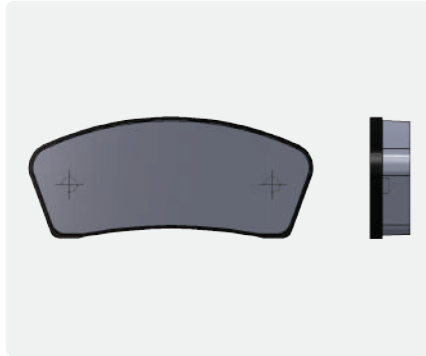

446-0

Height (mm) - **36,0** Thickness (mm) - **10,0**
Lenght (mm) - **40,8** Thread - /

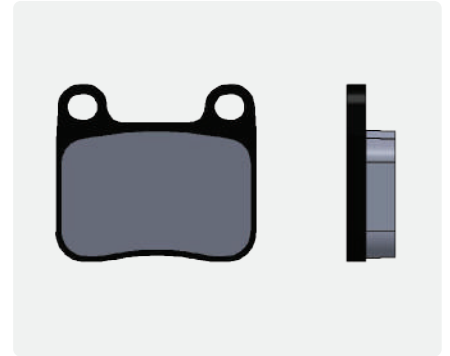

448-0

Height (mm) - **35,0** Thickness (mm) - **10,0**
Lenght (mm) - **73,0** Thread - **M6 60mm**

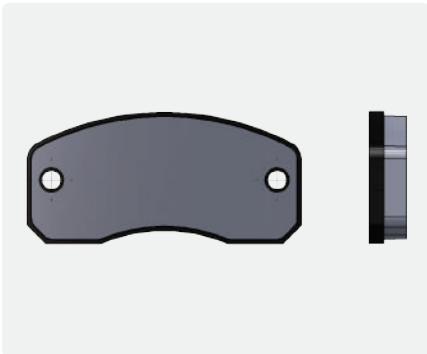

448-1

Height (mm) - **35,0** Thickness (mm) - **9,0**
Lenght (mm) - **73,0** Thread - **M6 60mm**

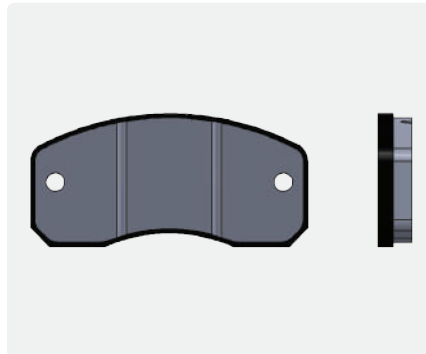

448-2

Height (mm) - **35,0** Thickness (mm) - **9,0**
Lenght (mm) - **73,0** Thread - **M6 60mm**

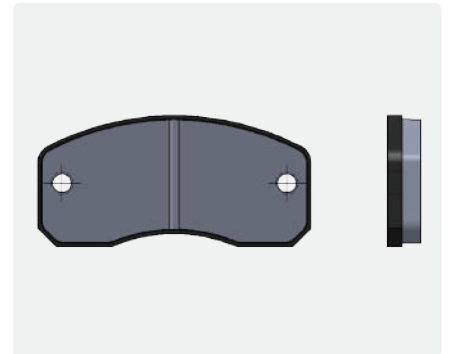

448-4

Height (mm) - **35** Thickness (mm) - **10,0**
Lenght (mm) - **73** Thread - **M6 60mm**

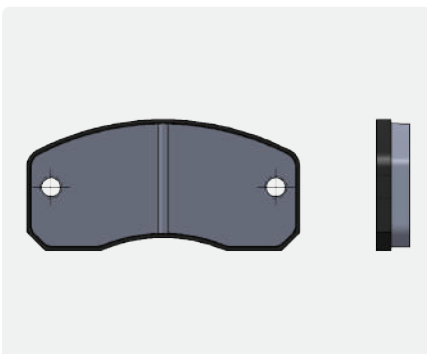

449-0

Height (mm) - **38,0** Thickness (mm) - **15,0**
Lenght (mm) - **88,4** Thread - **M6 65mm**

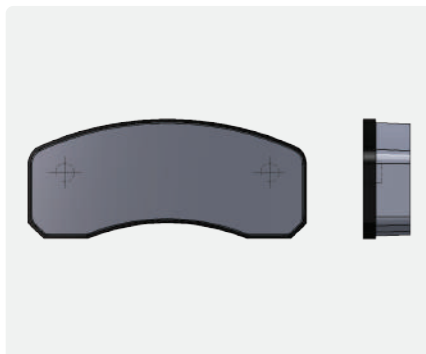

450-0

Height (mm) - **48,2** Thickness (mm) - **14,0**
Lenght (mm) - **108,0** Thread - **M6* 76mm**

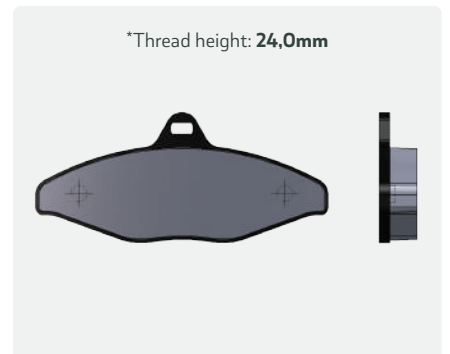

450-1

Height (mm) - **48,2** Thickness (mm) - **12,0**
Lenght (mm) - **108,0** Thread - **M6 97mm**

*Thread height: **26,0mm**

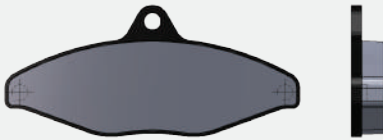

451-0

Height (mm) - **39,2** Thickness (mm) - **12,0**
Lenght (mm) - **145,6** Thread - /



452-0

Height (mm) - **47,4** Thickness (mm) - **12,2**
Lenght (mm) - **61,5** Thread - /



454-0

Height (mm) - **47,4** Thickness (mm) - **13,0**
Lenght (mm) - **61,5** Thread - /



455-0

Height (mm) - **48,8** Thickness (mm) - **14,0**
Lenght (mm) - **92,0** Thread - **M6 72mm**



456-0

Height (mm) - **45,9** Thickness (mm) - **10,0**
Lenght (mm) - **40,0** Thread - /

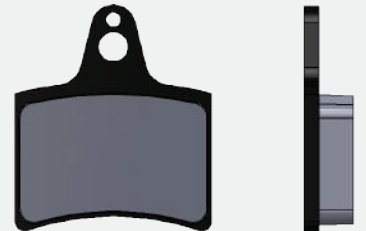

456-1

Height (mm) - **45,9** Thickness (mm) - **14,0**
Lenght (mm) - **40,0** Thread - /

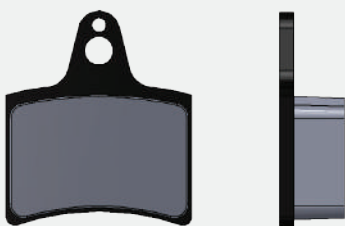

464-0

Height (mm) - **38,7** Thickness (mm) - **16,5**
Lenght (mm) - **79,0** Thread - **M6**



465-0

Height (mm) - **46,6** Thickness (mm) - **10,0**
Lenght (mm) - **82,0** Thread - **M6* 64mm**

*Thread height: **24,0mm**

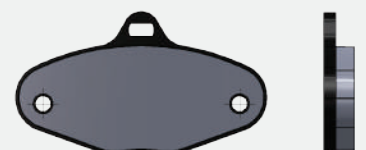

BRAKE PADS

466-0

Height (mm) - **50,8** Thickness (mm) - **13,6**
Lenght (mm) - **55,6** Thread - /

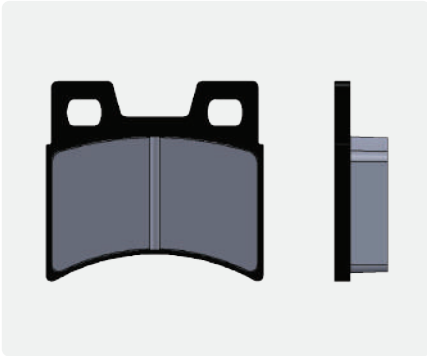

467-0

Height (mm) - **40,6** Thickness (mm) - **10,0**
Lenght (mm) - **83,5** Thread - **M6**

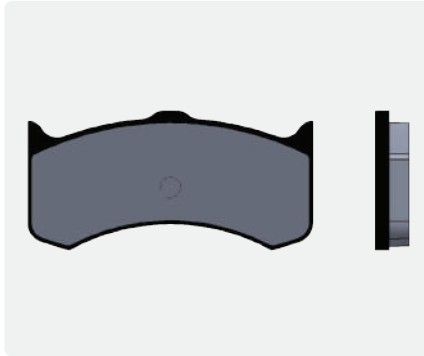

467-1

Height (mm) - **40,6** Thickness (mm) - **10,0**
Lenght (mm) - **83,5** Thread - **M6**

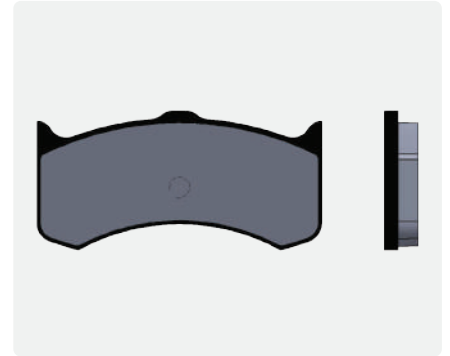

474-0

Height (mm) - **42,3** Thickness (mm) - **10,0**
Lenght (mm) - **55,8** Thread - /

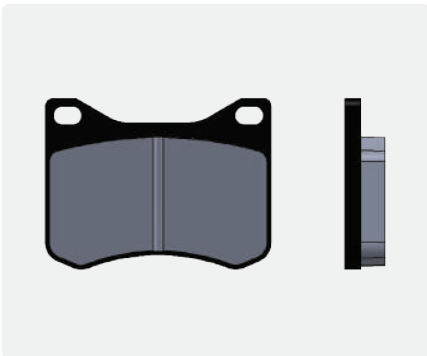

475-0

Height (mm) - **45,0** Thickness (mm) - **6,0**
Lenght (mm) - **36,0** Thread - /

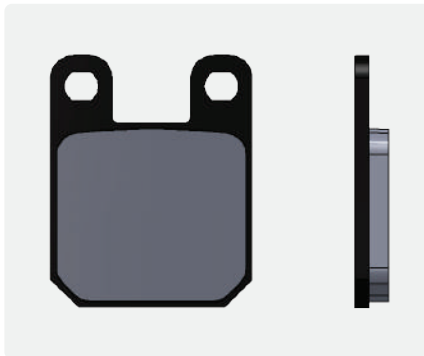

476-0

Height (mm) - **38,4** Thickness (mm) - **7,0**
Lenght (mm) - **41,0** Thread - /

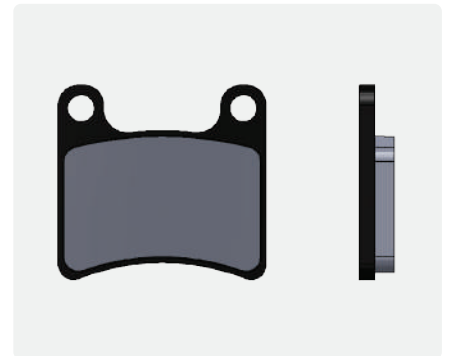

476-1

Height (mm) - **38,4** Thickness (mm) - **10,0**
Lenght (mm) - **41,0** Thread - /

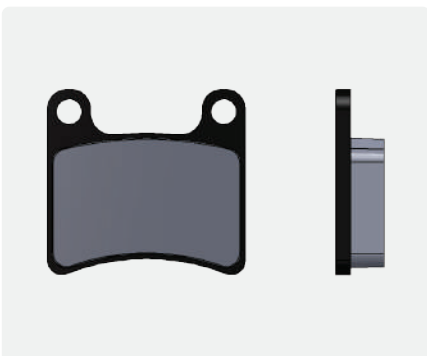

479-0

Height (mm) - **43,6** Thickness (mm) - **10,5**
Lenght (mm) - **79,8** Thread - **M5**

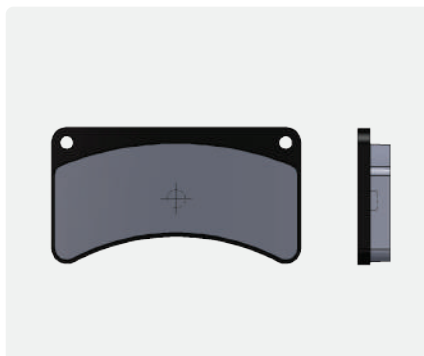

479-1

Height (mm) - **43,6** Thickness (mm) - **12,0**
Lenght (mm) - **79,8** Thread - **M5**

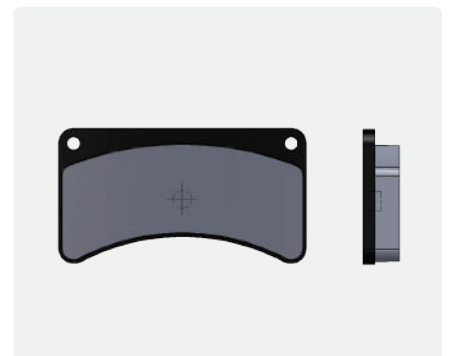

479-2

Height (mm) - **43,6** Thickness (mm) - **13,0**
Lenght (mm) - **79,8** Thread - **M5**

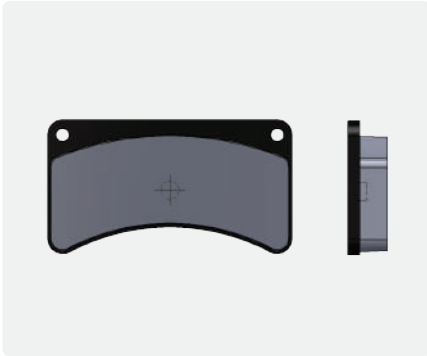

479-3

Height (mm) - **43,6** Thickness (mm) - **10,2**
Lenght (mm) - **79,8** Thread - /

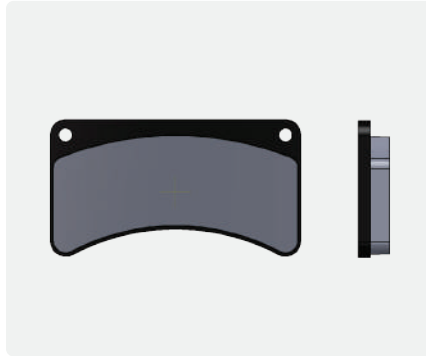

482-0

Height (mm) - **49,0** Thickness (mm) - **10,0**
Lenght (mm) - **48,0** Thread - /

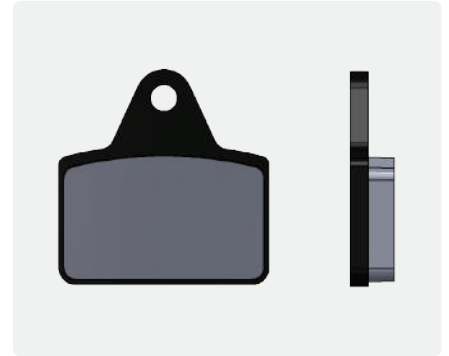

483-0

Height (mm) - **51,5** Thickness (mm) - **10,0**
Lenght (mm) - **85,0** Thread - **M6 74mm**

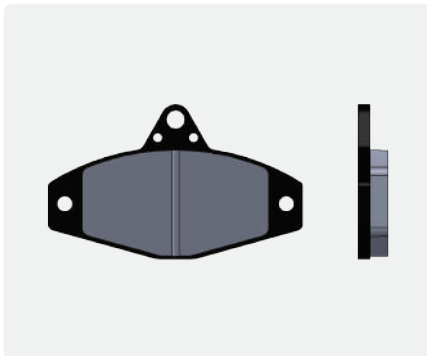

487-0

Height (mm) - **55,5** Thickness (mm) - **15,0**
Lenght (mm) - **88,4** Thread - **M6 65mm**

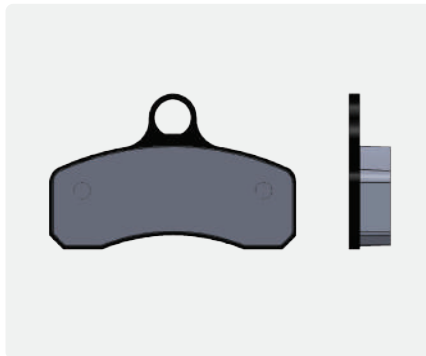

489-0

Height (mm) - **67,0** Thickness (mm) - **16,5**
Lenght (mm) - **70,0** Thread - **M6 60mm**

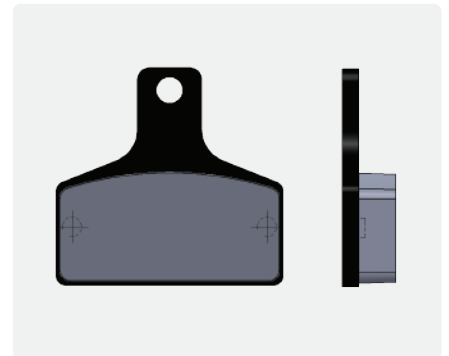

490-0

Height (mm) - **47,4** Thickness (mm) - **10,0**
Lenght (mm) - **92,1** Thread - **M6 74mm**

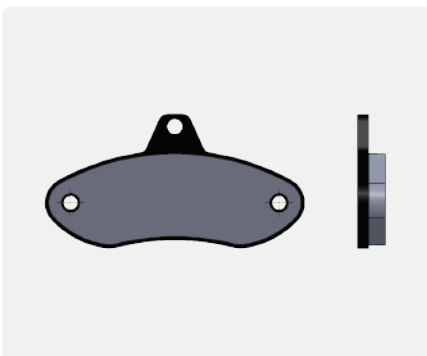

491-0

Height (mm) - **49,0** Thickness (mm) - **12,8**
Lenght (mm) - **89,6** Thread - **M6 65mm**

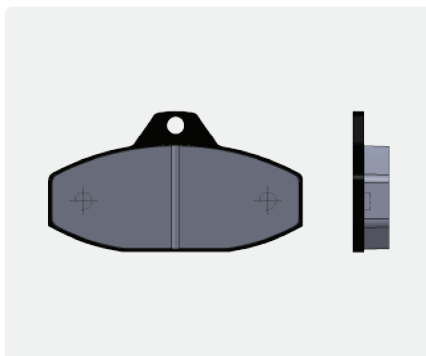

492-0

Height (mm) - **44,5** Thickness (mm) - **7,2**
Lenght (mm) - **73,8** Thread - **M4 54mm**

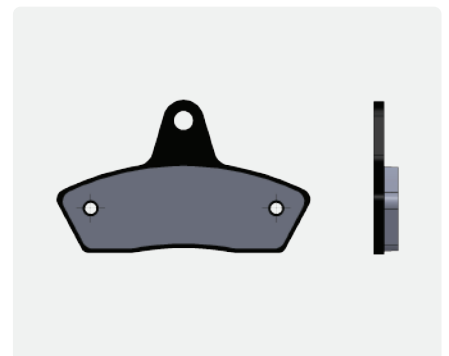

BRAKE PADS

492-1

Height (mm) - **44,5** Thickness (mm) - **9,8**
Lenght (mm) - **73,8** Thread - **M4 54mm**

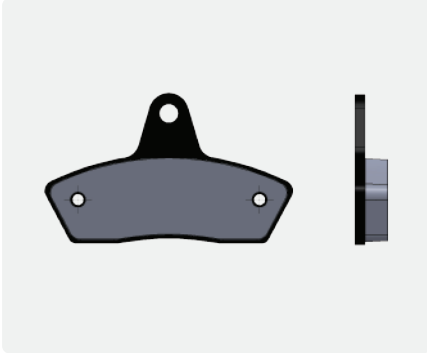

494-0

Height (mm) - **41,2** Thickness (mm) - **11,0**
Lenght (mm) - **88,8** Thread - /

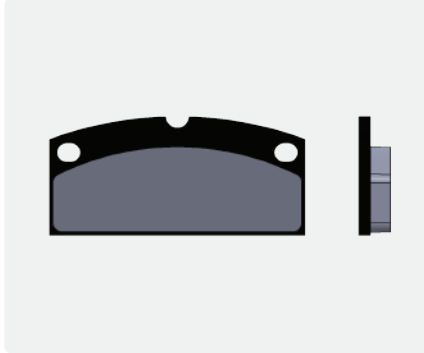

494-1

Height (mm) - **41,2** Thickness (mm) - **10,0**
Lenght (mm) - **88,8** Thread - /

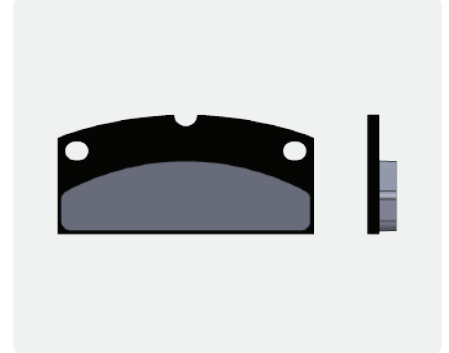

497-0

Height (mm) - **40,0** Thickness (mm) - **10,0**
Lenght (mm) - **60,0** Thread - /

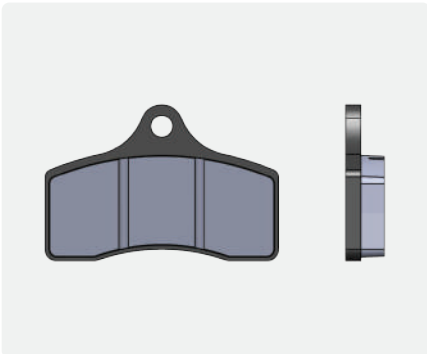

501-0

Height (mm) - **49,0** Thickness (mm) - **12,8**
Lenght (mm) - **89,6** Thread - **M6 65mm**

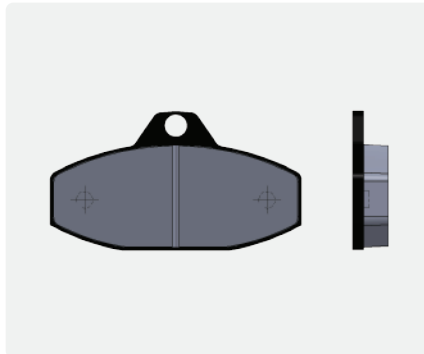

502-0

Height (mm) - **46,2** Thickness (mm) - **13,0**
Lenght (mm) - **80,0** Thread - **M6**

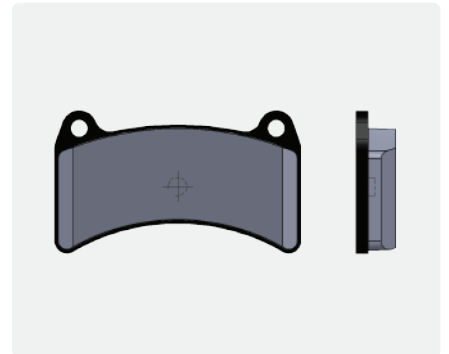

503-0

Height (mm) - **37,8** Thickness (mm) - **12,0**
Lenght (mm) - **60,0** Thread - /

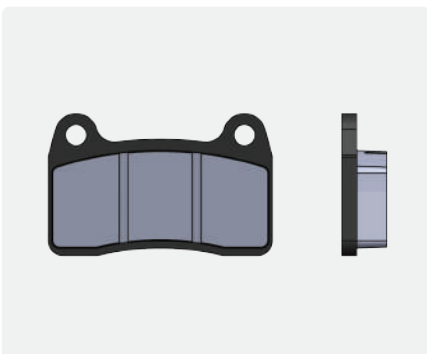

504-0

Height (mm) - **45,0** Thickness (mm) - **9,0**
Lenght (mm) - **42,8** Thread - /

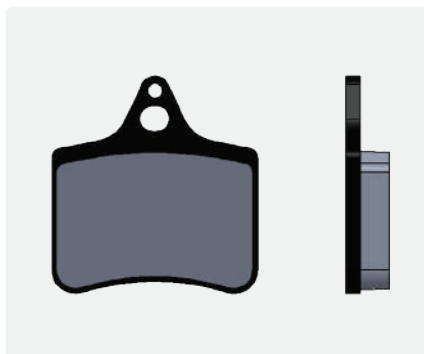

505-0

Height (mm) - **50,4** Thickness (mm) - **9,5**
Lenght (mm) - **59,4** Thread - /

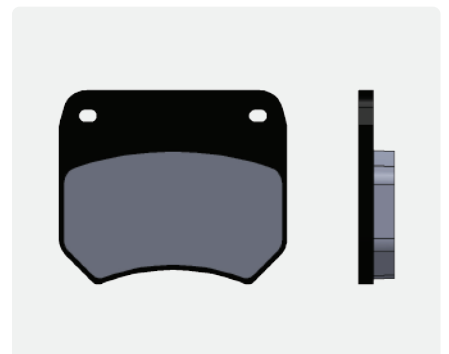

506-0

Height (mm) - **46,5** Thickness (mm) - **7,0**
Lenght (mm) - **39,9** Thread - /

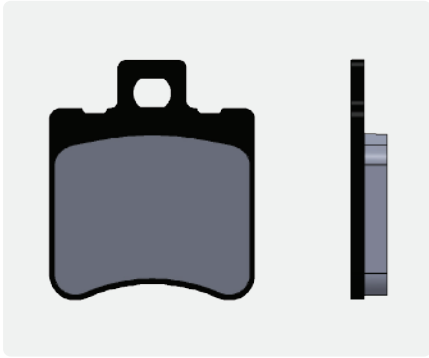

507-0

Height (mm) - **52,3** Thickness (mm) - **10,0**
Lenght (mm) - **53,8** Thread - /

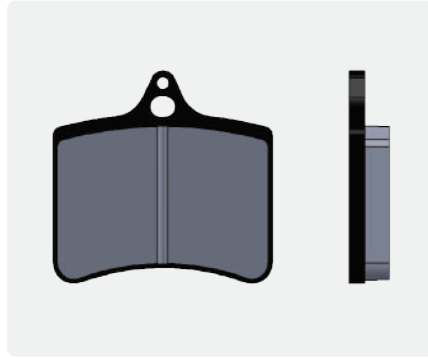

509-0

Height (mm) - **56,5** Thickness (mm) - **7,0**
Lenght (mm) - **40,0** Thread - /

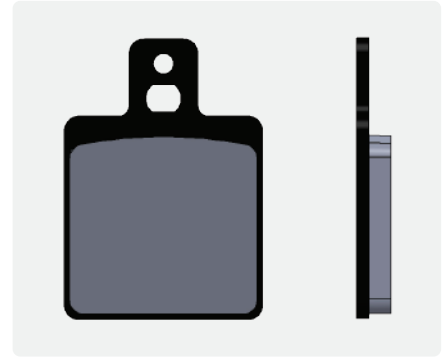

510-0

Height (mm) - **49,3** Thickness (mm) - **15,0**
Lenght (mm) - **100,0** Thread - **M6 74mm**

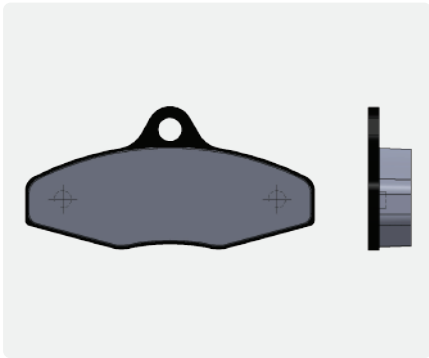

512-0

Height (mm) - **31,3** Thickness (mm) - **8**
Lenght (mm) - **52,9** Thread - /

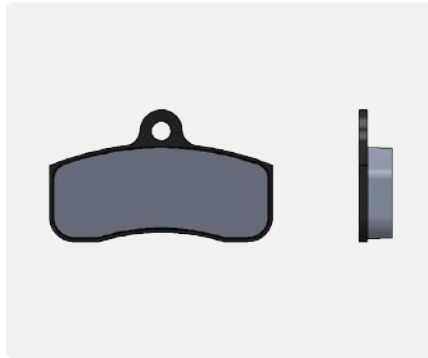

513-0

Height (mm) - **48,9** Thickness (mm) - **14,0**
Lenght (mm) - **69,8** Thread - **M5 58,8mm**

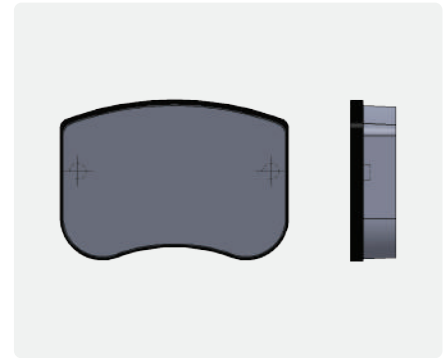

515-0

Height (mm) - **54,4** Thickness (mm) - **11,0**
Lenght (mm) - **74,8** Thread - **M5 28/65mm**

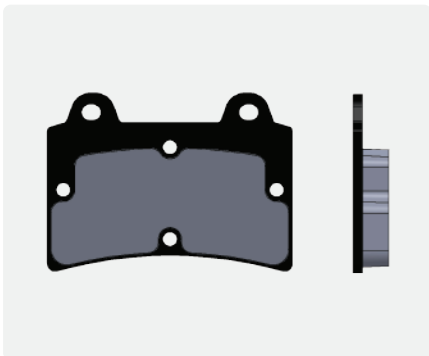

515-1

Height (mm) - **54,4** Thickness (mm) - **15,0**
Lenght (mm) - **74,8** Thread - **M5 28/65mm**

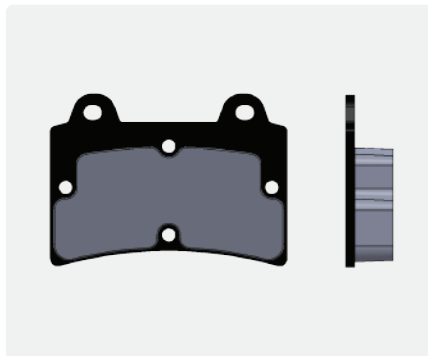

515-2

Height (mm) - **54,4** Thickness (mm) - **10,0**
Lenght (mm) - **74,8** Thread - **M5 28/65mm**

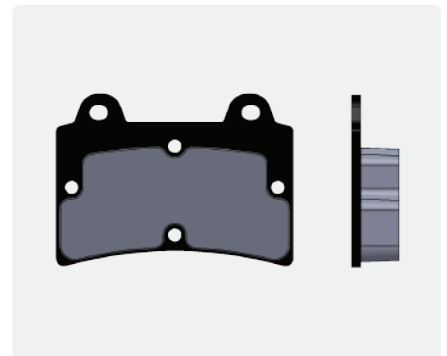

BRAKE PADS

516-0

Height (mm) - **50,6** Thickness (mm) - **12,0**
Lenght (mm) - **78,5** Thread - **M5 68mm**

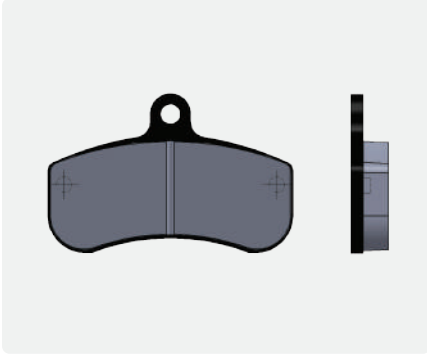

519-0

Height (mm) - **49,8** Thickness (mm) - **8,5**
Lenght (mm) - **37,9** Thread - /

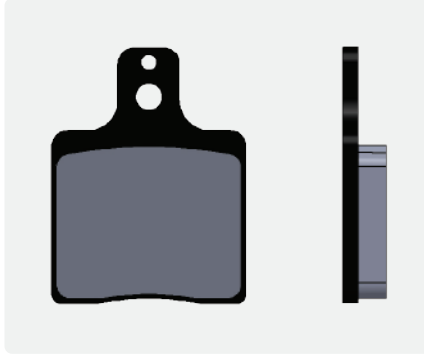

522-0

Height (mm) - **53,0** Thickness (mm) - **10,0**
Lenght (mm) - **37,5** Thread - /

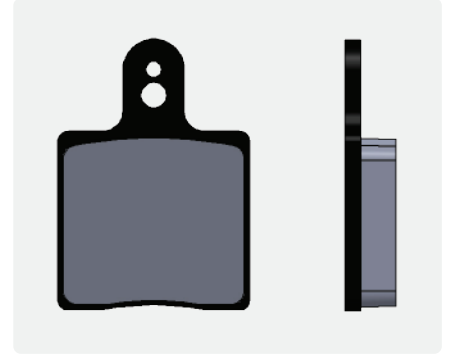

523-0

Height (mm) - **49,7** Thickness (mm) - **10,0**
Lenght (mm) - **37,1** Thread - /

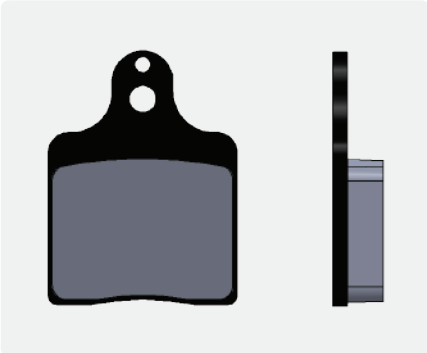

524-0

Height (mm) - **50,3** Thickness (mm) - **10,5**
Lenght (mm) - **61,6** Thread - **M4 44mm**

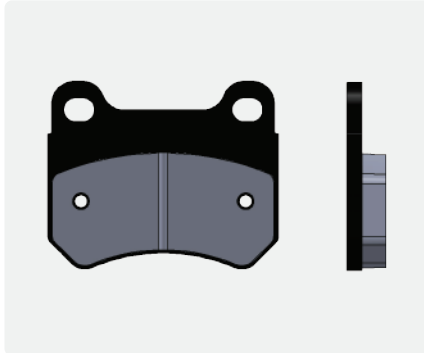

524-1

Height (mm) - **50,3** Thickness (mm) - **13,0**
Lenght (mm) - **61,6** Thread - /

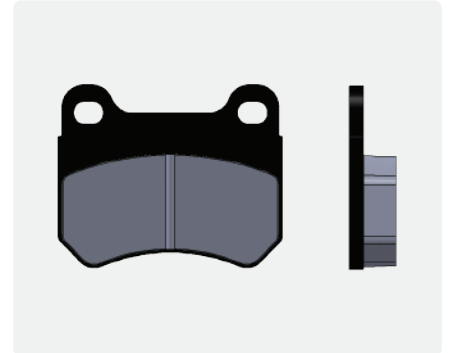

524-2

Height (mm) - **50,3** Thickness (mm) - **13,0**
Lenght (mm) - **61,6** Thread - **M6* 50mm**

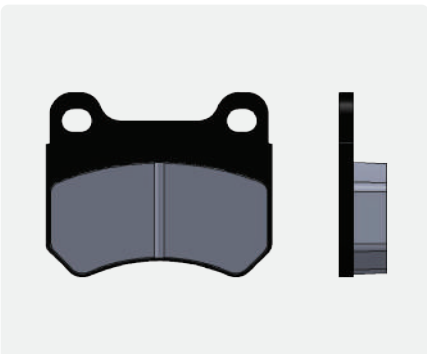

525-0

Height (mm) - **33,2** Thickness (mm) - **8,0**
Lenght (mm) - **108,0** Thread - /

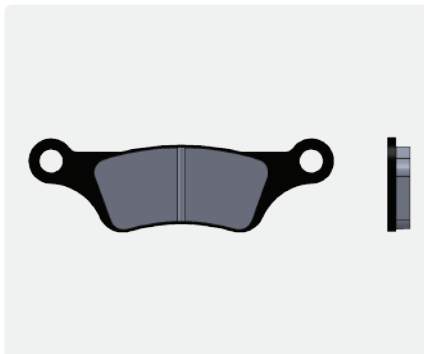

526-0

Height (mm) - **43,0** Thickness (mm) - **8,0**
Lenght (mm) - **41,8** Thread - /

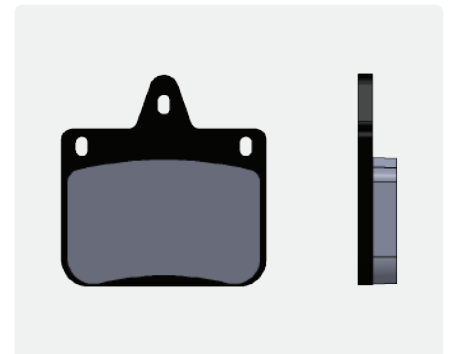

528-0

Height (mm) - **53,2** Thickness (mm) - **14,0**
Lenght (mm) - **135,2** Thread - **M6 90mm**

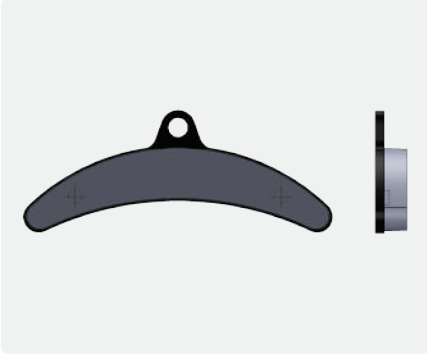

528-1

Height (mm) - **53,2** Thickness (mm) - **15,0**
Lenght (mm) - **135,2** Thread - **M6 90mm**

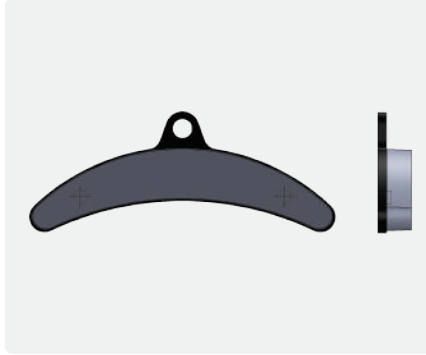

528-2

Height (mm) - **53,2** Thickness (mm) - **10,5**
Lenght (mm) - **135,2** Thread - **M6 110mm**

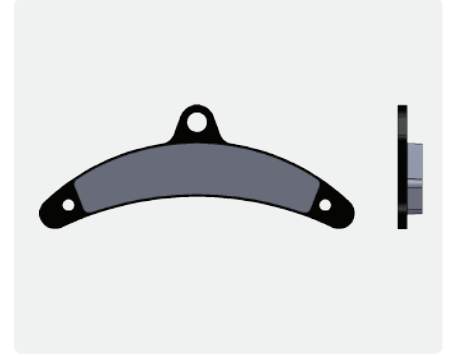

528-3

Height (mm) - **53,2** Thickness (mm) - **15,0**
Lenght (mm) - **135,2** Thread - **M6 90mm**

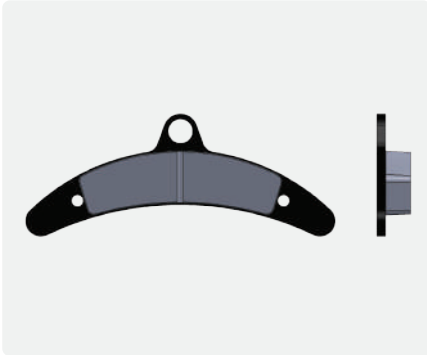

528-4

Height (mm) - **53,2** Thickness (mm) - **15,0**
Lenght (mm) - **135,2** Thread - **M6 90mm**



529-1

Height (mm) - **40,7** Thickness (mm) - **11,0**
Lenght (mm) - **100,0** Thread - **M5 80mm**

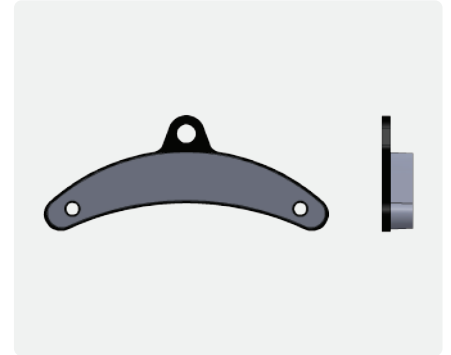

529-2

Height (mm) - **40,7** Thickness (mm) - **8,5**
Lenght (mm) - **100,0** Thread - **M5 80mm**



533-0

Height (mm) - **52,8** Thickness (mm) - **9,0**
Lenght (mm) - **52,5** Thread - /

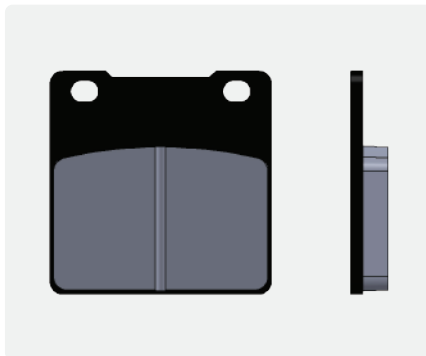

536-0

Height (mm) - **51,5** Thickness (mm) - **12,8**
Lenght (mm) - **81,7** Thread - /

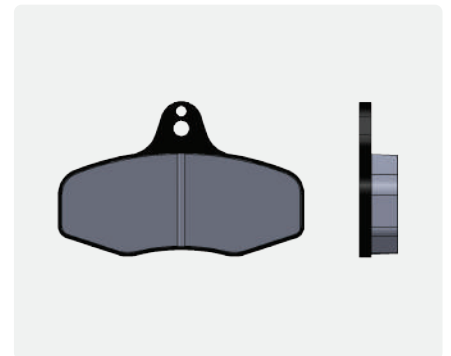

BRAKE PADS

537-0

Height (mm) - **44,0** Thickness (mm) - **10,0**
Lenght (mm) - **33,8** Thread - /

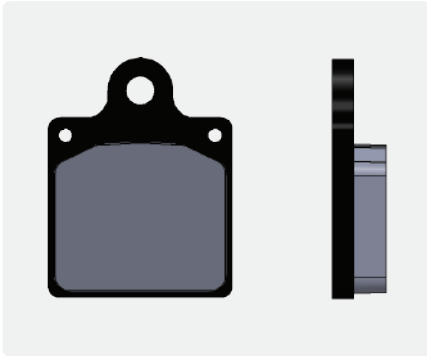

542-0

Height (mm) - **30,3** Thickness (mm) - **6,0**
Lenght (mm) - **47,9** Thread - /

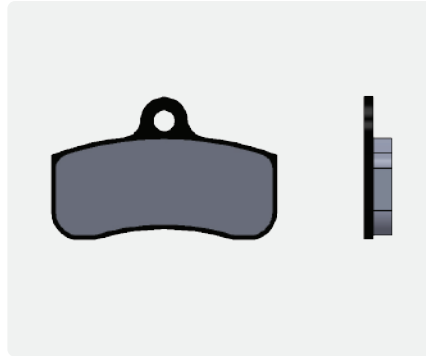

543-0

Height (mm) - **41,9** Thickness (mm) - **9,5**
Lenght (mm) - **63,9** Thread - **M5 24mm**

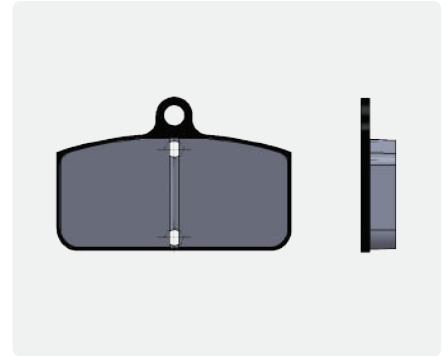

546-0

Height (mm) - **51,9** Thickness (mm) - **14,0**
Lenght (mm) - **70,0** Thread - /

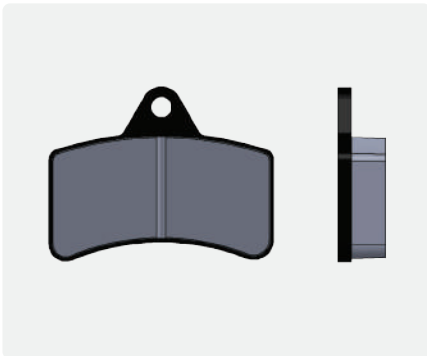

551-0

Height (mm) - **51,1** Thickness (mm) - **10,0**
Lenght (mm) - **86,0** Thread - **M6 74mm**

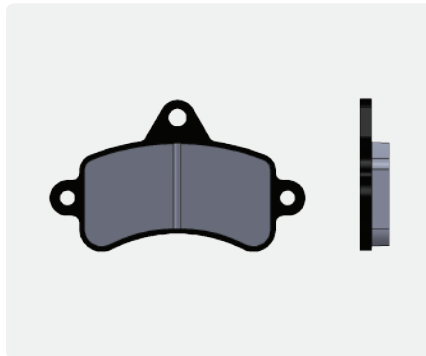

551-1

Height (mm) - **51,1** Thickness (mm) - **12,0**
Lenght (mm) - **86,0** Thread - **M6 74mm**

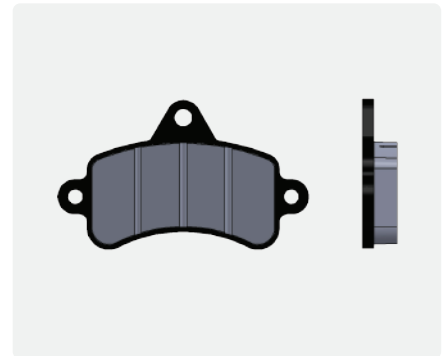

551-2

Height (mm) - **51,1** Thickness (mm) - **10,0**
Lenght (mm) - **86,0** Thread - **M6 74mm**

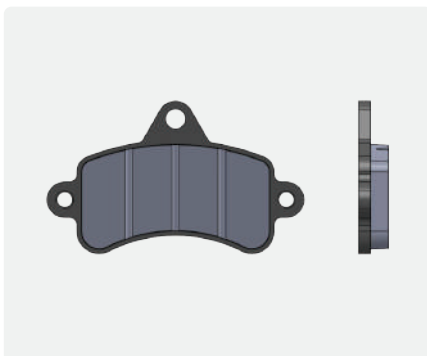

552-0

Height (mm) - **50,1** Thickness (mm) - **14,0**
Lenght (mm) - **86,0** Thread - **M6 74mm**

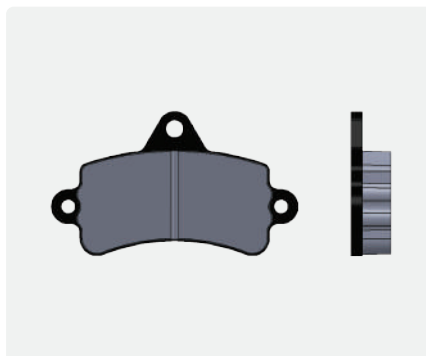

557-0

Height (mm) - **44,5** Thickness (mm) - **10,0**
Lenght (mm) - **55,8** Thread - /

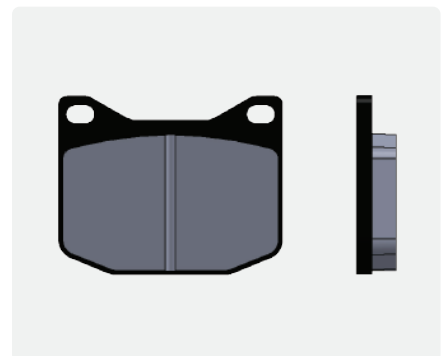

556-0

Height (mm) - **36,5** Thickness (mm) - **9,0**
Lenght (mm) - **44,8** Thread - /

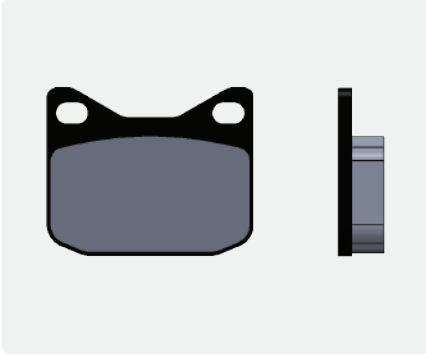

557-0

Height (mm) - **44,5** Thickness (mm) - **10,0**
Lenght (mm) - **55,8** Thread - /

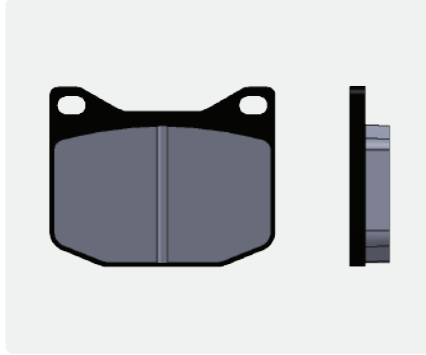

558-0

Height (mm) - **44,9** Thickness (mm) - **9,0**
Lenght (mm) - **66,5** Thread - **M6 41mm**

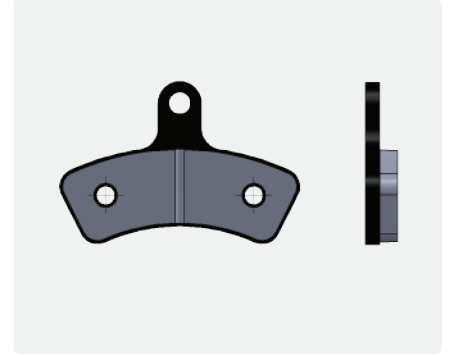

558-1

Height (mm) - **44,9** Thickness (mm) - **11,5**
Lenght (mm) - **66,5** Thread - **M6 41mm**

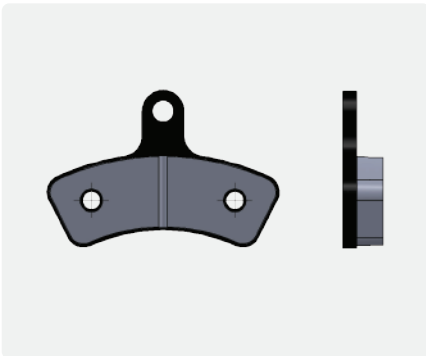

559-0

Height (mm) - **48,0** Thickness (mm) - **11,0**
Lenght (mm) - **70,0** Thread - **M6 60mm**

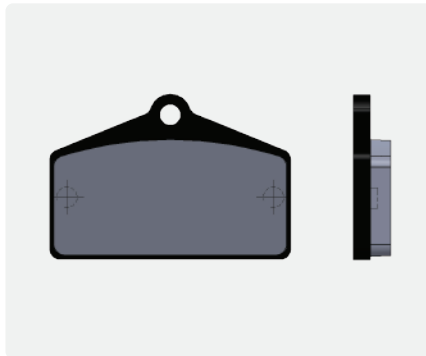

559-1

Height (mm) - **48,0** Thickness (mm) - **10,8**
Lenght (mm) - **70,0** Thread - **M6 60mm**

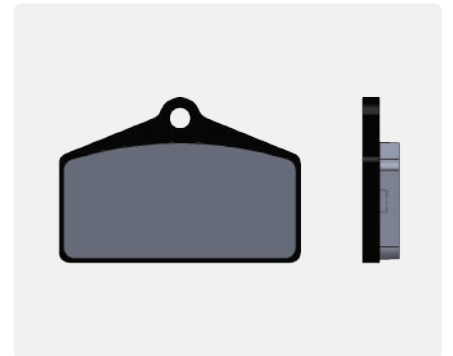

561-0

Height (mm) - **44,0** Thickness (mm) - **9,0**
Lenght (mm) - **52,0** Thread - **M6 41mm**

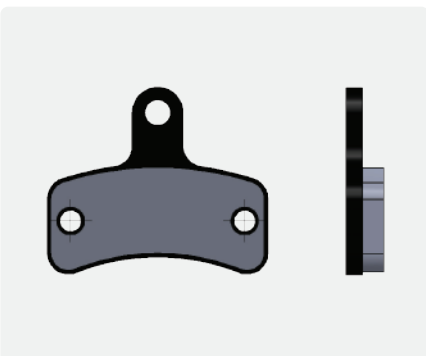

562-0

Height (mm) - **35,5** Thickness (mm) - **6,9**
Lenght (mm) - **68,8** Thread - **M4 54mm**

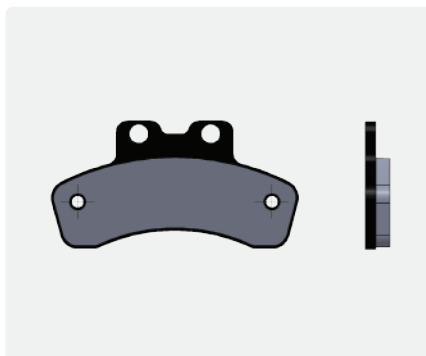

562-1

Height (mm) - **35,5** Thickness (mm) - **7,9**
Lenght (mm) - **68,8** Thread - **M4 54mm**

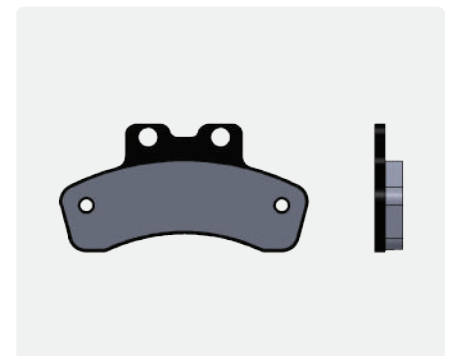

BRAKE PADS

563-0

Height (mm) - **45,0** Thickness (mm) - **9,0**
Lenght (mm) - **82,0** Thread - **M6 70mm**

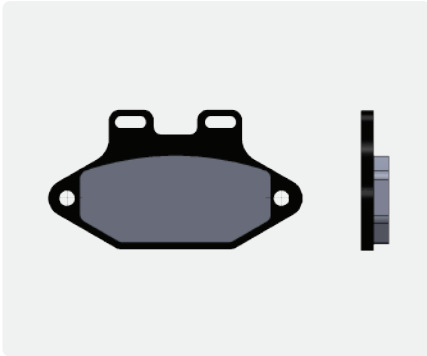

564-0

Height (mm) - **52,0** Thickness (mm) - **11,5**
Lenght (mm) - **91,0** Thread - **M6 65mm**

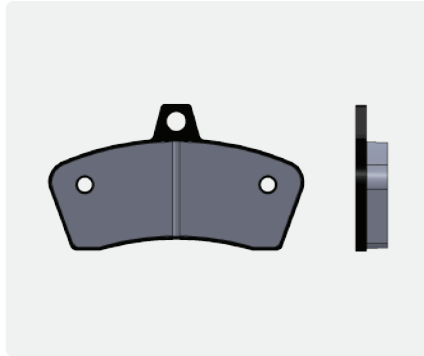

565-0

Height (mm) - **62,5** Thickness (mm) - **16,0**
Lenght (mm) - **81,0** Thread - /

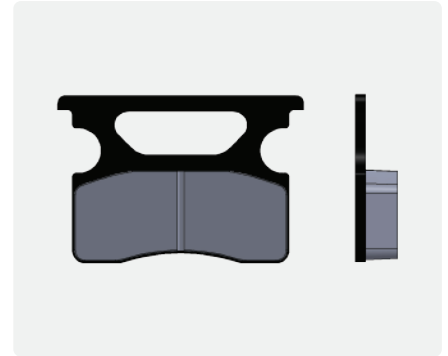

567-0

Height (mm) - **50,5** Thickness (mm) - **9,0**
Lenght (mm) - **44,8** Thread - /

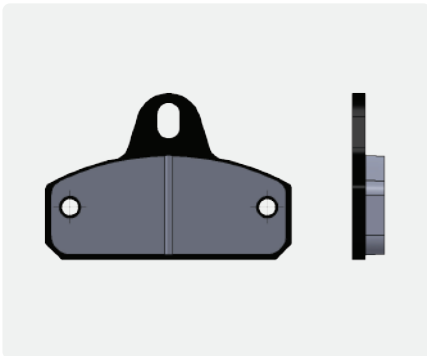

572-0

Height (mm) - **52,0** Thickness (mm) - **8,0**
Lenght (mm) - **40,0** Thread - /

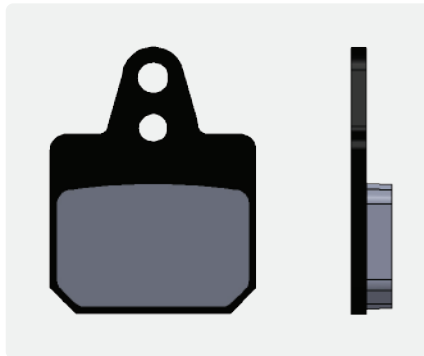

573-0

Height (mm) - **38,5** Thickness (mm) - **8,0**
Lenght (mm) - **42,0** Thread - /

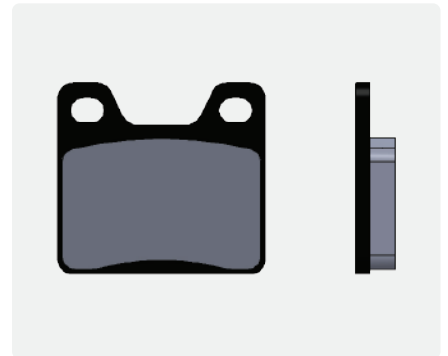

574-0

Height (mm) - **45,5** Thickness (mm) - **10,0**
Lenght (mm) - **56,0** Thread - /

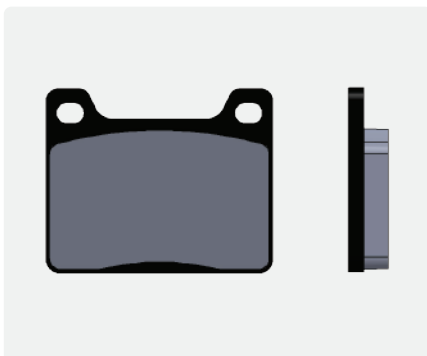

576-0

Height (mm) - **28,0** Thickness (mm) - **6,3**
Lenght (mm) - **26,9** Thread - /

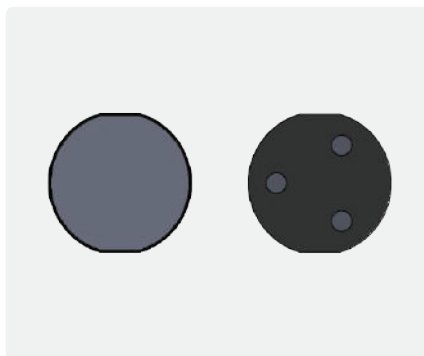

577-0

Height (mm) - **28,0** Thickness (mm) - **6,3**
Lenght (mm) - **26,9** Thread - /

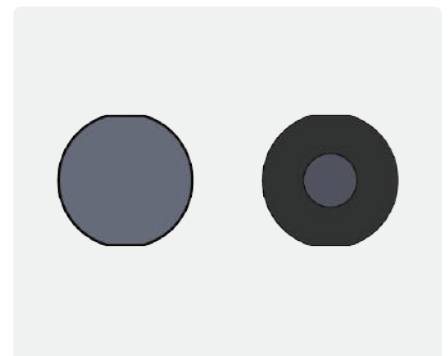

593-0

Height (mm) - **48,5** Thickness (mm) - **12,0**
Lenght (mm) - **58,0** Thread - /

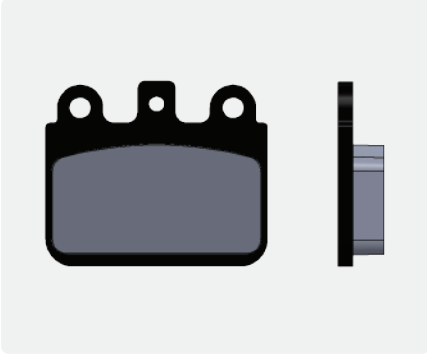

606-1

Height (mm) - **54,0** Thickness (mm) - **6,4**
Lenght (mm) - **39,8** Thread - /

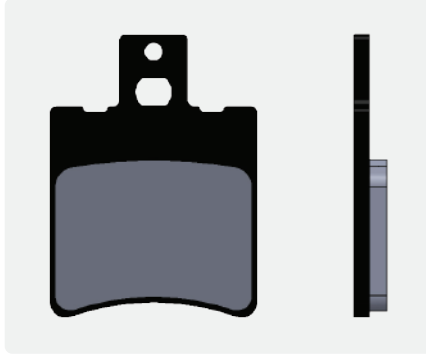

630-0

Height (mm) - **54,0** Thickness (mm) - **7,6**
Lenght (mm) - **50,9** Thread - /

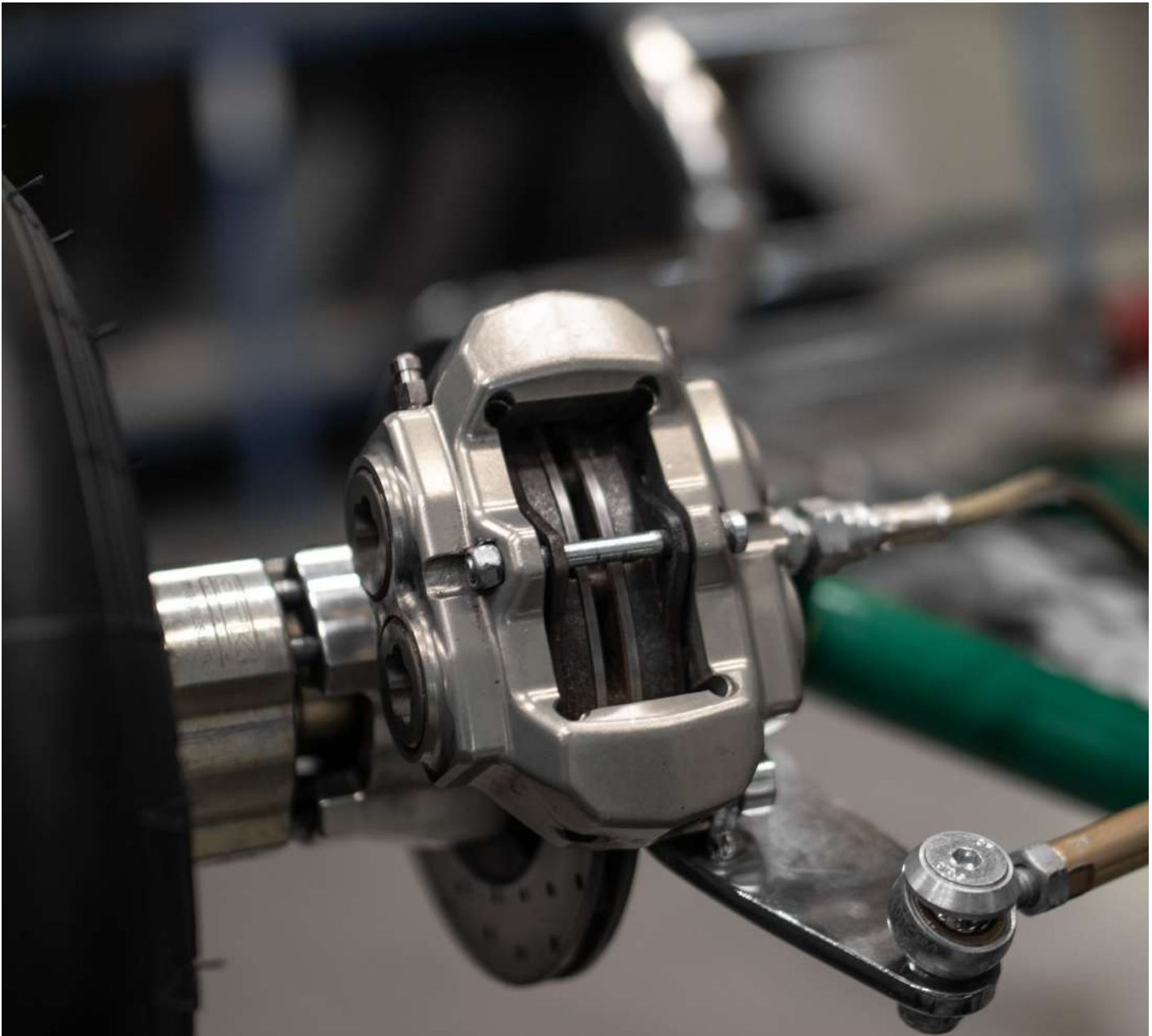
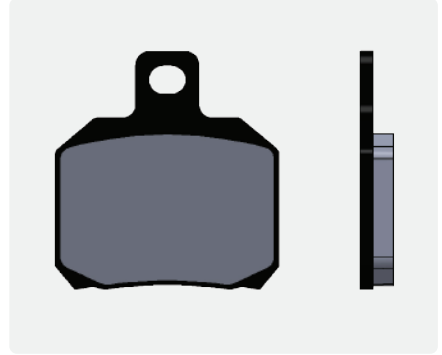

TABLE BY MANUFACTURERS

AMV	406-2	552-0	405-2	452-0
	406-4	576-0	405-3	454-0
519-0	410-0	COMEX	405-4	456-0
522-0	424-0		406-0	492-0
593-0	492-0	490-0	406-2	516-0
ARROW KART	528-0	494-0	406-4	562-0
	528-1	CRG	FA	562-1
515-0	528-2			INTREPID
515-2	529-1	450-0	490-0	
ATE	529-2	519-0	FIRST	409-0
	572-0	526-0		423-0
027-0	BREMBO	593-0	401-2	476-0
027-2		EKS	401-3	476-1
414-0	506-0		405-0	491-0
479-0	509-0	405-0	405-2	502-0
479-1	630-0	405-1	405-3	IPK
479-2	BRM	405-2	405-4	
479-3		405-3	406-0	429-0
505-0	454-0	405-4	406-2	476-0
506-0	456-0	406-0	406-3	476-1
BABY KART	459-0	406-2	406-4	491-0
	523-0	406-4	410-0	497-0
576-0	536-0	410-0	490-0	503-0
577-0	CHAROLETTE	516-0	GILLARD	536-0
BIREL		EL-ZET		KART COMPONENTS
	563-0		562-0	
098-0	CMP	402-0	563-0	027-6
401-2		573-0	564-0	092-5
401-3	491-0	574-0	GRIMECA	448-1
405-0	COMER-TOPKART	ENERGY CORSE		448-2
405-2			576-0	525-0
405-3	441-2	401-2	577-0	KELGATE
405-4	546-0	401-3	HAASE	
406-0	551-1	405-0		027-0

027-1	MAGURA	OTL	RIGHETTI RIDOLFI	SODI KART
027-2				
296-5	562-0	490-0	401-2	296-5
414-0	MARANELLO	494-0	401-3	407-0
479-0		494-1	403-0	512-0
479-1	475-0	PAROLIN	405-0	524-1
479-2	519-0		405-2	542-0
479-3	593-0	340-0	405-3	543-0
505-0	MBA	359-0	405-4	565-0
506-0		434-0	410-0	SWISS HUTLESS
K-KART	433-0	434-1	417-0	
	434-0	490-0	417-1	435-0
504-0	450-1	491-0	419-0	489-0
507-0	510-0	492-0	483-0	558-0
556-0	MS KART	510-0	593-0	558-1
557-0		524-1	RIMO	559-0
LENZO KART	433-0	533-0		559-1
	434-0	PCR	451-0	561-0
436-0	448-0		525-0	558-0
442-0	448-4	438-1	ROSSO CORSA	559-0
482-0	449-0	446-0		T-REX
567-0	450-1	540-0	433-0	
570-0	467-0	R3 RACING	434-0	564-0
MACH1	467-1		450-1	WILDKART
	510-0	027-0	502-0	
431-0	556-0	027-2	510-0	405-0
439-0	557-0	414-0	RUBIX	413-0
466-0	ORANGE	479-0		414-0
MADDOX		479-1	490-0	490-0
	476-0	479-2	GOLDSPEED	533-0
562-0	476-1	479-3		ZANARDI
563-0	502-0	505-0	478-0	
		506-0		537-0

GO FOR THE VICTORY, DO IT WITH



EXPERIENCE SINCE 1969

Brake pads for scooters, bike and go-kart, industrial friction components, special friction products and brake rotors.

CUSTOM-MADE

We focus on the extreme and personal needs of our customers in racing or rental segments. We develop & test in-house.

OWN PRODUCTION

Our new state-of-the-art plant covers 2500 sq. Meters, and we produce more than 2 million brake pads annually.

ENVIRONMENTALLY FRIENDLY

We meet all European safety and environmental requirements.



Sinter Ljubljana d.o.o.
Cesta v Mestni log 75
SI-1000 Ljubljana
Slovenia / Europe

Tel: +386 1 280 34 22
E-mail: sales@sinter.si