

# FICHE D'HOMOLOGATION / HOMOLOGATION FORM

015-B2-67



COMMISSION  
INTERNATIONALE  
DE KARTING - FIA



## SYSTEME DE FREINAGE / BRAKING SYSTEM 2 WP

Constructeur / <i>Manufacturer</i>	INTREPID DRIVER PROGRAM SRL
Marque / <i>Make</i>	<b>INTREPID</b>
Modèle / <i>Model</i>	<b>R3 20</b>
Catégorie / <i>Category</i>	Group 3
Durée de l'homologation / <i>Validity of the Homologation</i>	4 ans / 4 years
Nombre de pages / <i>Number of pages</i>	4
La présente Fiche d'Homologation reproduit descriptions, illustrations et dimensions du système de freinage au moment de l'homologation CIK-FIA.	<i>This Homologation Form reproduces descriptions, illustrations and dimensions of the braking system at the moment of the CIK-FIA homologation.</i>

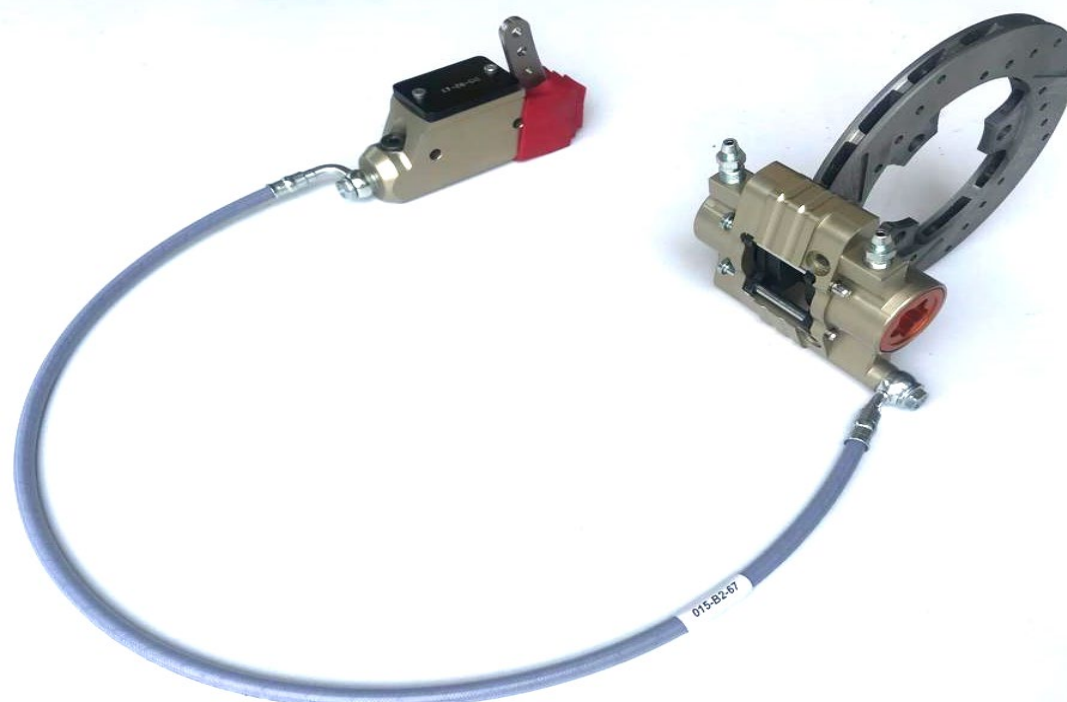

Photo vue de dessus du système complet / *Photo from above of complete system*

Signature et tampon de l'ASN /  
*Signature and stamp of the ASN*

Signature et tampon de la CIK-FIA /  
*Signature and stamp of the CIK-FIA*



*V. Ghidella*



A

**Dessin technique / Technical drawing**  
Dessin technique explosé / Exploded technical drawing

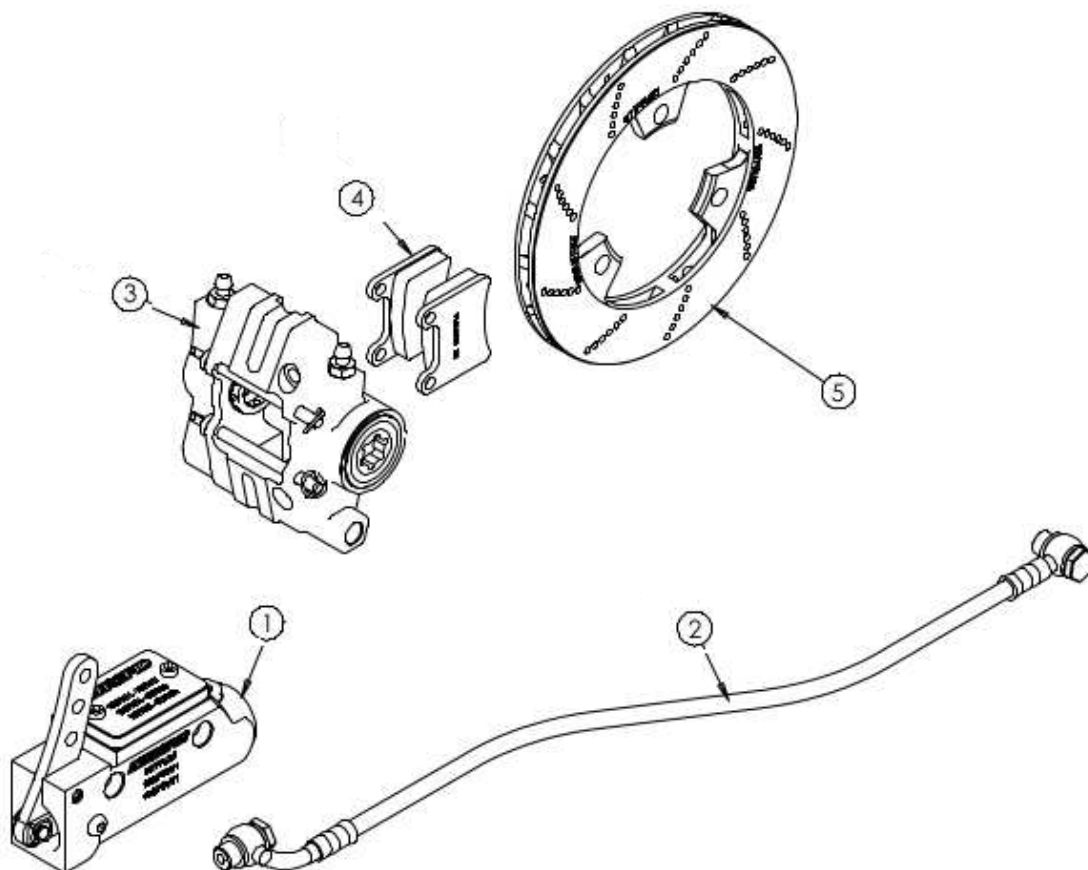

Le dessin technique doit montrer les éléments ci-après : maître-cylindre, régulateur, répartiteur, tuyaux, étriers, plaquettes et disques (numérotation selon tableau ci-dessous) /

*The technical drawing must show the following: Master cylinder, regulator, distributor, tubes, calipers, pads and discs (with numbering according to the table below)*

N°	Désignation / Designation	Référence catalogue / Catalogue reference
1	Maitre-cylindre / Master cylinder	I/INT0103
2	Tuyau / Tube	I/KITFR-P18
3	Etrier frein arrière / Rear brake calliper	I/PFAR1KSX-4WP
4	Plaquette frein arrière / Rear brake pad	I/PFAR1K-4WP-NR
5	Disque frein arrière / Rear brake disc	I/DFAR1K-4WP

B	<b>Description technique / Technical description</b>		
	Nombre de maître-cylindres / <i>Number of master cylinders</i>	1	
	Ø alésage / <i>Bore Ø</i>	19 mm	
	Nombre de pistons / <i>Number of pistons</i>	2	par étrier / <i>per caliper</i>
	Ø alésage de l'étrier / <i>Caliper bore Ø</i>	28 mm	
	Nombre de plaquettes / <i>Number of pads</i>	2	par étrier / <i>per caliper</i>
	Nombre d'étriers / <i>Number of calipers</i>	1	
	Matériau des étriers / <i>Caliper material</i>	Alu	
	Disque ventilé / <i>Ventilated disc</i>	Oui / <i>Yes</i>	
	Epaisseur du disque neuf / <i>Thickness of new disc</i>	11 mm	± 1 mm
	Ø extérieur du disque / <i>External Ø of the disc</i>	150 mm	± 1.5 mm
	Longueur hors-tout des plaquettes / <i>Overall length of the pads</i>	45 mm	± 1.5 mm
	Longueur du matériau de friction / <i>Length of the friction material</i>	43 mm	± 1.5 mm
	Hauteur du matériau de friction / <i>Height of the friction material</i>	25 mm	± 1.5 mm

C	<b>Photo du frein arrière / Photo of rear brake</b>		
			
	Etrier et disque uniquement / <i>Caliper and disc only</i>		

D	Photo du marquage du numéro d'homologation / Photo of the homologation number marking	
	Maitre-cylindre / Master cylinder	Tuyau / Tube
		
	Etrier / Caliper	Plaquettes / Pads
		
	Disques / Discs	
		
<p>Le marquage doit rester clairement visible en permanence. / The marking must be clearly visible at all times.</p>		